

**WHITEMARSH TOWNSHIP
SHADE TREE COMMISSION MEETING AGENDA
FEBRUARY 3, 2026 AT 6:30 PM (IN-PERSON)**

CHRISTIAN FASSBENDER (Chair) ___ VERA KOSABUTSKI (Vice-Chair) ___
NATALIE BORKOWSKI ___ DAVID D'AMORE ___ FRAN KELLY ___

BOS LIAISON, JACY TOLL ___ ARBORIST, JOHN HOSBACH ___
STAFF LIAISON, SAMANTHA ZRILLO ___

CALL TO ORDER:

ANNOUNCEMENTS:

- All speakers are requested to speak directly into the microphones.

APPROVAL OF MINUTES:

- January 6, 2026

PLAN REVIEWS:

- Grading Permit #2025-22 Stenton Ave. Trust; Construction of Single-Family Dwelling & Associated Improvements; PARCEL ID 65-00-11131-009

OLD BUSINESS:

- Abolition Hall- Tree Project Update
- Continued Discussion on Chapter 55 Amendments—Schedule Special Meeting

NEW BUSINESS:

- Tree Planting—Valley Green Park

PUBLIC COMMENT PERIOD:

BOARD MEMBER COMMENTS:

NEXT MEETING DATE: Tuesday, March 3, 2026

| | | | |
|-------------|------------|----------------------------|------------|
| January 6 | February 3 | March 3 | April 7 |
| May 5 | June 2 | July 7 | August 4 |
| September 1 | October 6 | November 3 Election Day | December 1 |

ADJOURNMENT:

PUBLIC PARTICIPATION INFORMATION

1. Public meetings of the Commission shall follow a prescribed agenda, which will be available to the general public no later than the Friday preceding the meeting.
2. If members of the public wish the Commission to address a specific item at a public meeting, a written request to the Staff Liaison shall be submitted at least one week before the meeting. The written request shall specify the item or items the individual desires to be addressed.
3. The Commission may consider other matters for the agenda as they see fit.
4. The Commission will entertain Public Comment at the conclusion of the discussion of the item and prior to specific action on the item during the meeting, at the discretion of the Chair. Individuals must advise the Chair of their desire to offer such comment.
5. A Public Comment period will be provided at the conclusion of a meeting for input on any new subject.
6. The Commission Chair shall preside over Public Comments and may within their discretion:
 - a. Recognize individuals wishing to offer comment.
 - b. Require identification of such persons.
 - c. Allocate total available Public Comment time among all individuals wishing to comment.
 - d. Allocate up to a five (5) minute maximum for each individual to offer Public Comment at a meeting, Township Staff shall time comments and shall announce, "one minute remaining" and "time expired" to the Chair.
 - e. Rule out of order scandalous, impertinent and redundant comment or any comment the discernible purpose of which is to disrupt or prevent the conduct of the business of the meeting including the questioning of, or polling of, or debating with, individual members of the Commission.

**WHITEMARSH TOWNSHIP
SHADE TREE COMMISSION MEETING MINUTES
JANUARY 6, 2026**

Members Present: Christian Fassbender, Vera Kosabutski, Natalie Borkowski, David D'Amore, and Fran Kelly. Also in attendance: Jacy Toll, Samantha Zrillo (Staff), and John Hosbach (Arborist).

CALL TO ORDER: Mr. Fassbender called the meeting to order at 6:33 PM.

ELECTION OF CHAIR: Ms. Kelly made a motion to nominate Christian Fassbender to be the Chair. Mr. D'Amore seconded the motion. Motion carried 3-0-1. Mr. Fassbender abstained. Ms. Borkowski was not in attendance at the time of the vote.

ELECTION OF VICE CHAIR: Ms. Kelly made a motion to nominate Ms. Kosabutski as Vice-Chair. Mr. D'Amore seconded the motion. Motion carried 3-0-1. Ms. Kosabutski abstained. Ms. Borkowski was not in attendance at the time of the vote.

ANNOUNCEMENTS:

- All speakers are requested to speak directly into the microphones.
Mr. Fassbender reminded everyone to speak in the microphones because the meeting is being recorded to assist with meeting minutes.

APPROVAL OF MINUTES:

- November 18, 2025
Mr. D'Amore made a motion to approve the November 18, 2025 meeting minutes. Ms. Kosabutski seconded the motion. Motion carried unanimously (4-0). Ms. Borkowski was not in attendance at the time of the vote.

PLAN REVIEWS:

- Grading Permit #2025-10 Green Valley Country Club R1 (201 Ridge Pike); Padel Court Location Change [Chair Fassbender revised the agenda to hear this Grading Permit second because the project representative was not yet in attendance.]

In attendance: Darrell Campana, PLA, Eustace Engineering, Applicant's Representative

The applicant's representative returned to the Shade Tree Commission to present revised plans for the Green Valley Country Club padel courts, proposing replacement of an existing tennis clay court with a concrete surface and padel court system. Shrubs and a 6" tree are to be removed and arborvitae is proposed to be planted. The applicant requested waivers related to tree survey requirements and tree protection fencing due to plan revisions and a change in court location.

Discussion included proposed screening along the courts, involving non-native arborvitae. Mr. Hosbach said that native red cedars can also provide screening. It was determined that the arborvitae would grow faster. A member of the Commission also commented on existing vegetation, including black walnut trees along the roadway.

Public in attendance: Debra Harris (resident)

Ms. Harris mentioned that consideration should be given to planting native species on the property to replace the 6" tree being removed.

A member of the Commission agreed with Ms. Harris. Mr. Campana said that can be done.

Ms. Borkowski made a motion to grant the following waivers, conditioned on the planting of two, 3” redbud trees on the property:

- **55-4.C.(3) to waive the requirement of a tree survey for the entire site and limiting it to the area depicted on the plans near the limit of disturbance**
- **55-4.C.(4)(b) to waive the tree protection fencing requirements as written in the ordinance and allow the protection fencing to be placed as shown on the plans**

Ms. Kosabutski seconded the motion. Motion carried unanimously (5-0).

- Grading Permit #2025-25 Madras Investments 1, LLC (400 Stenton Ave); Building Addition
In attendance: Wick Littleton, Owner

The applicant gave an overview of the existing conditions of the site and proposed removing existing lean-to and metal structures and constructing a new building on existing blacktop. No trees would be removed, and all construction would remain within existing impervious areas. The applicant noted that approximately 12–14 foot cedar trees had already been planted along the existing retaining wall visible from Joshua Road.

Mr. Hosbach noted that the site contains limited scrub and invasive vegetation outside the limits of disturbance.

Waivers were requested for tree inventory, landscape plan, and tree protection requirements, as well as for concrete washout provisions, since a washout location was not shown on the plan. Mr. Littleton said that he can obtain a concrete washout dumpster.

There was discussion about the extent of the construction and where the concrete washout would be located. A Commission member stated that they would like the applicant to consider additional landscaping.

There was no public comment.

Mr. D’Amore made a motion to grant the following waivers as all disturbance will be on existing impervious surface, subject to the inclusion of the washout dumpster:

- **§55-4.C. to waive the requirement of having a tree survey and landscape plan**
- **§55-4.D. to waive tree protection and preservation requirements**

Ms. Borkowski seconded the motion. Motion carried unanimously (5-0).

- Grading Permit #2025-24 Union League Liberty Hill, LLC (800 Ridge Pike); Construction of New Ballroom and Associated Improvements
In attendance: Greg Newell, P.E., Nave Newell, Applicant’s Engineer; Jared Lowman, RLA, Nave Newell, Applicant’s Consultant; Michelle Christensen, General Manager, Union League

Mr. Newell explained that the project includes renovations to the clubhouse and golf course, including work to consolidate a ballroom on the eastern side of the building. He noted a timing issue related to the grading permit review, during which it was identified that six trees would be removed and therefore require replacement. Due to construction starting later than expected, the applicant proactively planted about 30 replacement trees in the fall to get ahead of the replacement requirement and ensure they were established before spring. Mr. Newell requested a waiver to allow the project to receive credit for the replacement trees already planted, identifying their locations along Barren Hill Road to improve screening and along Hart’s Lane to provide additional buffering for a nearby residence and maintenance/parking areas. He also noted one larger tree near the rear of the clubhouse (near the former helipad area) would need to be removed in the future due to ADA access constraints.

A member of the Commission asked what trees were planted. Mr. Lowman responded: 18 Norway spruce, 12 White spruce, and 6 Siberian spruce. Mr. Hosbach mentioned that the replacement requirement for this project would be 17.33 (rounded to 18 trees). Commission members discussed the request, noting concerns regarding ordinance compliance, specifically the requirement of canopy (shade) trees over evergreens, native species requirements, and the potential precedent of granting credit for pre-planted trees. A member

of the Commission expressed dissatisfaction of having the evergreen trees replace the trees to be removed and said that canopy trees should be planted. Another member questioned if the evergreen species planted were native. Mr. Hosbach responded that the Norway is not native and the White spruce is native. Mr. Hosbach asked if the applicant would consider planting 10, 3" native canopy trees. Ms. Christensen said yes.

Public in attendance: Steve Kaufman (resident); Debra Harris (resident)

Public comment was received from Steve Kaufman, who expressed concern about setting a precedent for retroactive credit for tree plantings and emphasized that waivers should be granted only where hardship exists and ordinance intent is met. He noted that replacement requirements prioritize canopy trees and suggested additional native shade trees be planted rather than relying primarily on evergreens. Later in the meeting, Mr. Kaufman mentioned that the planting of 10 canopy trees would still leave the applicant short (without consideration of the evergreens). Debra Harris commented on the importance of meeting native species percentage requirements and questioned if the requirement was being met with the addition of the 10 trees. Mr. Hosbach said yes.

There was further discussion about the tree replacement calculations. Mr. Hosbach said that a total of 52 inches of tree caliper is being removed, which—using the three-inch replacement standard—equates to approximately 17.5 replacement trees. The applicant has already proactively planted 30 or 32 evergreen trees (8–10 feet), which are estimated to be equivalent to 2.5–3-inch trees. Although evergreens are typically measured by height and width rather than caliper inches, Mr. Hosbach stated that if the Township accepts credit for the proactive plantings, the applicant would exceed the replacement requirement with an additional 10 trees also referenced as further offsetting the removal.

Following discussion, Ms. Borkowski made a motion to grant waivers and accept credit for the previously planted evergreen trees, conditioned on the applicant planting an additional ten native canopy trees (minimum three-inch caliper) elsewhere on the property and revising the plans to reflect all replacements. Waivers included:

- **55-4.C. to waive the requirement of a tree survey for the entire site and limiting it to the area depicted on the plans near the limit of disturbance**
- **55-4.D.(6)(a) to allow the previously planted evergreen trees be considered as replacements, whereas it is required that every living and healthy tree removed is to be replaced with one or more canopy trees**

Ms. Kelly seconded the motion. Motion carried unanimously (5-0).

OLD BUSINESS:

- **Abolition Hall- Tree Project Update**
John Hosbach provided an update on Abolition Hall, noting that a more complete report would follow an upcoming inspection scheduled for the next day. He stated that he had been in contact with the contractor and that, while communication had been limited, the work appeared to be progressing satisfactorily. A compliance inspection would be conducted on site by Ms. Zrillo, Mr. McAnally (Township Manager), and himself, to verify that approved removals were completed, no property damage or rutting occurred in agreed-upon areas, and that chipped material had been evenly distributed within the woodland. Mr. Hosbach also commented that the contractor performed quality work along Butler Pike, describing the results as well executed.
- **2026 Tree Giveaway Species**
The Commission reviewed the proposed 2026 Township Tree Giveaway species list and discussed species diversity, climate adaptability, evergreen characteristics, and anticipated nursery availability. It was noted that final availability would not be confirmed until mid to late summer.

Public in attendance: Steve Kaufman (resident)

Mr. Kaufman asked for clarification about the Sweet Bay. Mr. Fassbender and Mr. Hosbach said that it is a multi-stemmed, semi evergreen. There was a discussion about the preference of evergreen options.

Mr. D'Amore made a motion to approve the provided list with flexibility, directing staff, Mr. Hosbach, and Karen Kabnick, to prioritize species and develop alternate options as needed

based on availability. Ms. Kelly seconded the motion. Motion carried unanimously (5-0).

- Continued Discussion on Chapter 55 Amendments
The Commission agreed that additional time was needed to develop priorities and next steps. Members determined that further discussion would remain in a public forum. Staff indicated that work would continue offline to prepare a memo outlining priorities, which would be brought back to the Commission for review. It was agreed that dedicated time would be scheduled at a future meeting, with the goal of providing a draft memo in March.

NEW BUSINESS: (none)

PUBLIC COMMENT PERIOD: (none)

BOARD MEMBER COMMENTS: Mr. D'Amore mentioned that the Vice-Chair, Ms. Kosabutski, should sit next to Chair Fassbender at future meetings.

Mr. Hosbach congratulated Ms. Zrillo on her AICP credential (American Institute of Certified Planners).

Ms. Toll said that at the Board of Supervisors re-organization meeting, they voted to modify the public comment time to 3 minutes with the ability to allow more time. The Commission took the comment under advisement.

NEXT MEETING DATE: Tuesday, February 3, 2026

Mr. Fassbender noted that the next meeting is Tuesday, February 3, 2026. Ms. Toll said she will not be in attendance.

ADJOURNMENT: Ms. Kosabutski made a motion to adjourn the meeting. Mr. D'Amore seconded the motion. Motion carried unanimously. Meeting adjourned at 7:33 PM.



WHITEMARSH TOWNSHIP
APPLICATION FOR MINOR EARTH DISTURBANCE PERMIT and/or
REGULATED EARTH DISTURBANCE ACTIVITY

Date Filed: _____ Date of Completed Application Accepted: _____

Property Owner: Stenton Avenue Trust c/o Fred Zaspel

Address: 20 Limekiln Pike, Glenside, PA 19038

Phone #: _____ Fax #: _____ Email: [REDACTED]

Location of Property: Block: 47 Unit(s): 32

Billing Address: 20 Limekiln Pike, Glenside, PA 19038

Phone #: _____ Fax #: _____ Email: _____

Scope of Work: Construct single family dwelling with associated drives, walks, etc.

Does the proposed work affect any other property in any way?

No Yes, please describe: The Applicant is proposing to construct an access path from this property to the adjoining property owned by a family member. This access path will require minor grading and construction of the path on the neighboring property.

Application must be accompanied by **two (2) copies** of the plan, prepared in accordance with the requirements of Chapter 58 of the Township Code: Grading Erosion Control, Stormwater Management and Best Management Practices. **Five (5) copies of the final plan** must be submitted to the Township for final approval.

Details of the Proposed Work: Cubic Yards of fill/excavated materials: 1,000

Square Feet of new impervious coverage: 8,473

Square Feet of earth disturbance: 32,000

Date of Work to begin: March 2026 Date of Work to be completed: March 2027

Work being performed by: Rockwell Custom
(if other than owner)

Phone #: 215-983-8546 Fax #: _____ Email: connor@rockwellcustom.com

All work to be in conformance with all applicable Whitemarsh Township Codes & Ordinances including any amendments thereto.

Signature on original application _____

Signature of Applicant

Date



Applicant Name: Stenton Avenue Trust c/o Fred Zaspel

Development Name: Stenton Avenue (Vacant Lot)

Location of Property: Stenton Avenue, Plymouth Meeting, PA 19426

Date: _____

PROJECT COVER SHEET – *Approved at June 6, 2023 Shade Tree Commission Meeting*

To verify fulfillment of Chapter 55 Ordinance requirements for:

1. *Maximum Tree Removal – 55-4B*
2. *Tree Replacement – 55-4D(6)(a)*
3. *Substitutions for Replacements – 55-4F*
4. *Replacement Tree Species – 55-4E*
5. *Tree and Shrub requirements for Chapters other than Chapter 55*

Complete the following tables, filling in data for each lettered item, and resolving each Compliance Test. In accordance with 55-4C(4)(e), provide this completed Cover Sheet together with the Landscape Plan.

Citations to Sections of Chapter 55 are provided for the convenience of the Applicant. Other Chapters of the Whitemarsh Township Code and other sections of Chapter 55, such as 55-2 Definitions, may be relevant. In the event of an inconsistency between this Cover Sheet and any provision of the Code, the language of the Code shall be controlling.

1) Calculation of Requirement for Maximum Tree Removal – 55-4B:

| | | |
|----|--|----|
| A. | Total of all existing Trees on the lot with DBH of 6” or greater, per 55-4C(3)(a). | 97 |
| B. | 33% of line (A) = maximum existing Trees which may be Removed. | 32 |
| C. | Provide number of existing Trees proposed to be Removed by the Applicant, per 55-4C(3)(a). | 21 |
| | COMPLIANCE TEST: <i>If Line (C) is greater than Line (B), the Applicant’s proposal is not in compliance with the requirement that no more than 33% of trees having a DBH of six inches or greater may be removed.</i> | |



2) Calculation of Replacement Requirement for Removed Trees having a DBH of Six Inches or Greater 55-4D(6)(a):

| | | |
|----|---|----|
| D. | Total DBH of all existing Living and Healthy Trees (as determined per 55-4A) having a DBH of 6” or greater that are proposed to be Removed , per 55-4C(3)(a). | 6 |
| E. | Total DBH of all Living and Healthy Trees (as determined per 55-4A) having a DBH of 6” or greater, removed within five years prior to the submission of application , per 55-4C(3)(b). | 54 |
| F. | Sum of line (D) and line (E) = Total DBH that must be replaced for all Removed Living and Healthy Trees. | 60 |
| G. | Total Caliper inches of Canopy Replacement Trees proposed to be planted by the Applicant (as shown on the Landscape Plan) per 55-4D(6)(a). Each Canopy Replacement Tree shall have a minimum Caliper of three inches. | 60 |
| | COMPLIANCE TEST: If Line (G) is less than Line (F), the Applicant’s proposal is not in compliance with the minimum Canopy Tree Replacement Requirement. To comply with this requirement, the Applicant may request a waiver from the Shade Tree Commission to permit limited substitutions per 55-4F. If so, proceed to Substitution calculation (3) below. | |

3) Calculation of maximum Proposed Substitutions for Replacement Canopy Trees – 554F, subject to certain limitations and approval by the Shade Tree Commission.

| | | |
|----|---|----|
| H. | 40% of line (F) (round fractions <u>down</u> to a whole number) = maximum Caliper of required Replacement Canopy Trees that may be substituted with Understory Trees and/or FIL, upon STC approval, per 55-4F. | 24 |
| I. | Line (F) less Line (G) = Shortfall in DBH compliance with the minimum Canopy Tree Replacement Requirement , per 55-4D(6)(a). | 0 |
| | COMPLIANCE TEST: If line (H) is less than line (I), the deficit of minimum Canopy Tree Replacement requirement, per 55-4D(6) cannot be fully compensated with Substitutions, per 55-4F. | |



| | | |
|----|---|----|
| J. | Line (I) divided by 3" (round fractions <u>up</u> to a whole number) = Shortfall in the <u>number</u> of required 3" Canopy Replacement Trees. | 0 |
| K. | Provide the total number of substitution Understory Trees proposed to be planted by the Applicant, per 55-4F(1). | 0 |
| L. | Line (K) divided by two = Number of required 3"-cal. Replacement Canopy Trees being substituted with Understory Trees per 55-4F(1). | 0 |
| M. | Line (J) less Line (L) = Number of required 3"-cal. Replacement Canopy Trees proposed by the Applicant to be substituted with payment of in-lieu fees , per 55-4F(2). NOTE: Review proposed Landscape Plan to ensure that the use of Replacement Understory Tree substitutes has been maximized prior to calculating the number of substitutes via in-lieu fees, per 55-4F(4). | 0 |
| N. | Sum of Line (L) and Line (M) = Total proposed number of Replacement Canopy Trees being substituted per 55-4F. | 0 |
| O. | Line (N) multiplied by 3" = Total shortfall of DBH to be fulfilled with substitutions as proposed by this Landscape Plan. | 0 |
| | COMPLIANCE TEST: If (O) is greater than (H), the Applicant's proposal has exceeded the 40% maximum eligible for consideration for Replacement substitutions, per 55-4F, and is not in compliance. | |
| P. | Sum of Line (O) and (G) = Total Caliper compensation for Removed Trees as provided by this proposed Landscape Plan. | 60 |
| | COMPLIANCE TEST: If (P) is less than (F), the Applicant's proposal is not in compliance with the Tree Replacement Requirement. | |

4) Compliance with Species Requirement of Replacement Trees – 55-4E:

| | | |
|----|---|----|
| Q. | Total number of proposed Canopy Replacement Trees , per 55-4C(4)(c). | 20 |
|----|---|----|



| | | |
|----|---|----|
| R. | 75% of line (Q) (round fractions <u>up</u> to the next whole number) = Minimum required number of Native Species Replacement Canopy Trees, per 55-4E. | 15 |
| S. | Provide the number of proposed Native Species Canopy Replacement Trees, per 55-4C(4)(c). | 20 |
| | COMPLIANCE TEST: If Line (S) is less than Line (R), the Applicant's proposal is not in compliance with the 75% Native Species requirement for Replacement Canopy Trees, per 55-4E. | |
| T. | Provide the number of proposed Native Species Understory Trees. | 0 |
| | COMPLIANCE TEST: If Line (T) is less than line (K), he Applicant's proposal is not in compliance with the 100% Native Species requirement for Replacement Understory Trees. | |



5) Compliance with Landscaping Requirements of Other Code Chapters. Complete the following Tables for each applicable requirement.

REQUIRED TREES:

| A | B | C | D* | E | F** |
|---|---|------------------------|---|------------------------|--|
| Full Code Citation: Chapter; sub-chapter, etc. | Subject matter as indicated in Code caption | Required # of Trees | Credits for Preserved Trees per 55-4D(5) | Proposed # of Trees | Column (C) less Columns (D) and (E) |
| § 55-4D(6) | Replacement Tree Requirement | 20 | N/A | 20 | 0 |
| | | | | | |
| | | | | | |
| | | | | | |
| | | | | | |

***NOTE: Column (D) Credits are strictly limited to calculating Chapter 105-52 Buffer yards, in accordance with 55-4D(5).**

****NOTE: When the result in Column (F) is greater than zero, the Applicant's proposal is not in compliance with the applicable Code requirement.**

REQUIRED SHRUBS:

| A | B | C | D | E* |
|---|---|-------------------------|-------------------------|-------------------------------|
| Full Code Citation: Chapter; sub-chapter, etc. | Subject matter as indicated in Code caption | Required # of Shrubs | Proposed # of Shrubs | Column (C) less Column (D) |
| | | | | |
| | | | | |



| | | | | |
|--|--|--|--|--|
| | | | | |
|--|--|--|--|--|

****NOTE: When the result in Column (E) is greater than zero, the Applicant's proposal is not in compliance with the applicable Code requirement.***



Monika Buczko, RCA #785, BCMA PD-2392BF, CTSP, TCIA QT
Redwood Consulting Arborists, LLC
Warminster PA 18974
(267)663-3338
Redwoodarborists.com
redwoodarborists@hotmail.com

File No. 793

January 16, 2025

Client:

Name: Jim Zaspel

Address: 75 Stenton Ave, Plymouth Meeting PA 19462

Ph#: 267-577-1072, alt. contact: Andrew Chubb (Chubb tree service) 267-772-7478

Email: jimthehouseguypa@gmail.com

Tree Inspection Report in Support of Proposed Tree Removal Permit Application

Dear Mr. Zaspel,

Thank you for contacting Redwood Consulting Arborists and for the opportunity to assess your trees in relation to a proposed tree removal application to Whitemarsh Township. Enclosed please find my report, which presents my observations and recommendations regarding the trees proposed for removal, as well as those removed in spring 2025.

During site visits conducted on November 10, 2025, and January 14, 2026, I performed a visual inspection of trees proposed for removal that measured six inches or greater in diameter at breast height (DBH). Based on the site plan you provided, nineteen trees meeting this criterion were identified and inspected. In addition, eight trees were removed from the property in 2025.

Following evaluation of the health and condition of the subject trees and consideration of their potential impacts during and after construction, I determined that three trees require replacement in accordance with the township ordinance. Based on the combined DBH of these trees, a total of twenty three-inch caliper replacement trees are required.

A proposed list of replacement species is also included for your consideration.

Please do not hesitate to contact me should you have any questions or require additional information.

Sincerely,

Monika Buczko

Background & History

On November 4, 2025, Mr. Chubb of Chubb Tree Service contacted Redwood Consulting Arborists to request an inspection of approximately eight stumps located on the property of his client, Mr. Zaspel. These trees were removed by Mr. Chubb's company in spring 2025.

Following the removals, Mr. Zaspel received correspondence from the township requiring the planting of more than sixty (60+) replacement trees. Mr. Chubb requested that I conduct a site visit to assess the remaining stumps and prepare a report summarizing my findings. The purpose of the inspection was to identify the tree species where possible, evaluate the pre-removal condition of the trees, and determine whether removal was warranted due to hazardous conditions.

In addition, Mr. Zaspel requested an inspection of several additional trees proposed for removal in connection with planned construction on the property.

Assignment

During discussions with Mr. Zaspel and Mr. Chubb, I agreed to provide the following services:

- Conduct a site visit and meet with Mr. Zaspel and Mr. Chubb.
- Determine the location, DBH, and condition of trees removed in spring 2025.
- Identify and mark trees recommended for removal to accommodate proposed construction.
- Provide recommendations for suitable replacement tree species.
- Prepare a letter report for submission to the township.

After reviewing the circumstances and discussing the terms of engagement, I agreed to proceed with the inspection. A site visit was scheduled for November 10, 2025, at 8:00 a.m.

Limitations of the Assignment

My opinions and conclusions are based solely on a site visit, visual inspection of the remaining stumps and trees proposed for removal, and information provided to me through conversations with involved parties. Observations were limited to ground-level inspection only; no aerial inspection was conducted. This inspection does not constitute a tree risk assessment.

Purpose and Use of Report

The purpose of this report is to present my assessment of the trees removed in 2025, as well as recommendations regarding the removal of trees that interfere with the proposed structures and recommendations for tree replacement. This report is intended for use as part of the tree removal application process with Whitmarsh Township.

This report is confidential and intended solely for the use of Mr. Zaspel. It may be shared only with Whitmarsh Township and relevant contractors as necessary for the tree removal application and associated work. The contents of this report shall not be altered, excerpted, edited, or distributed, including via social media or online platforms, without the prior written consent of Redwood Consulting Arborists.

Observations

Site Visit

During my initial site visit, and with the assistance of Mr. Chubb, I identified eight trees that had been removed from the property. Of these, five stumps remained on site, while three trees had either fully decayed or had been completely removed (Appendix A). The approximate locations of the removed trees were noted on the property survey (Appendix B).

During this visit, I observed that the survey provided to me was outdated and did not accurately represent the locations or DBH of the existing trees.

I returned to the property on January 14, 2026, with an updated survey. During this visit, I identified nineteen trees proposed for removal to accommodate construction and grading activities (Appendix C). These trees were noted on the property survey (Appendix D), and an additional updated survey indicating tree numbers was also provided (Appendix E). At that time, Mr. Zaspel advised that construction of the pool and woodshed would be postponed and that the trees located in those areas would be retained for the time being (Appendix F).

For all subject trees, I recorded species, DBH, and observed condition, and documented my findings in accompanying spreadsheets. Photographs of all trees were taken for reference and are included in Appendix G.

Testing and Analysis

All subject trees were identified to species, measured at diameter at breast height (4.5 feet above grade), and their condition was noted. No soil testing or other diagnostic analyses were performed. The collected data are recorded in Appendices A and B.

Conclusion and Recommendations

Based on the DBH of the subject trees, I determined that a total of twenty (20) replacement trees, each measuring three (3) inches in caliper at six inches above grade, as required under the applicable township ordinance.

I propose the following species as a replacement option:

Large Trees

Oaks (*Quercus* spp.)

- White oak — *Quercus alba*
- Northern red oak — *Quercus rubra*
- Black oak — *Quercus velutina*
- Chestnut oak — *Quercus montana*
- Scarlet oak — *Quercus coccinea*
- Pin oak — *Quercus palustris*
- Swamp white oak — *Quercus bicolor*
- Willow oak — *Quercus phellos*

Maples (*Acer* spp.)

- Red maple — *Acer rubrum*
- Sugar maple — *Acer saccharum*

Hickories

- Shagbark hickory — *Carya ovata*
- Pignut hickory — *Carya glabra*
- Mockernut hickory — *Carya tomentosa*
- Bitternut hickory — *Carya cordiformis*

Birches

- River birch — *Betula nigra*
- Yellow birch — *Betula alleghaniensis*
- Sweet birch — *Betula lenta*

Other Large Trees

- American sycamore — *Platanus occidentalis*
- American beech — *Fagus grandifolia*
- Sweetgum — *Liquidambar styraciflua*
- Black gum — *Nyssa sylvatica*

- American elm (disease-resistant cultivars preferred) — *Ulmus americana*

Evergreens

- Eastern white pine — *Pinus strobus*
- Virginia pine — *Pinus virginiana*
- Eastern redcedar — *Juniperus virginiana*

Appendix A – trees removed in 2025 spreadsheet

| File #793 | | | | | |
|--|-----------------------|--------------------------|-----------------|----------------------------|-------------|
| 10-Nov-25 | | | | | |
| 75 Stenton Ave, Plymouth Meeting PA 19462 | | | | | |
| Tree Inventory - trees removed in spring 2025 | | | | | |
| Tree# | Species (common name) | Latin | DBH (inches) | Condition | Replacement |
| 20 | Pin oak | <i>Quercus palustris</i> | 28 | dieback, yellowing, dying | NO |
| 21 | Red maple | <i>Acer rubrum</i> | 20 | dead | NO |
| 22 | Maple | <i>Acer sp.</i> | no DBH recorded | tree was rotted and dead | NO |
| 23 | No ID | | no DBH recorded | not recorded | YES |
| 24 | No ID | | no DBH recorded | not recorded | YES |
| 25 | Willow oak | <i>Quercus phellos</i> | 29 | dead | NO |
| 26 | Pin oak | <i>Quercus palustris</i> | 30 | decay, upper half was dead | NO |
| 27 | White pine | <i>Pinus strobus</i> | 26 | tree was rotted and dead | NO |
| 3 trees have no recorded DBH (diamter at breast height measured 4.5 feet above ground level) | | | | | |
| Average of the 5 redorded DBH is 26.6 | | | | | |
| Total trees to be replaced: 2 | | | | | |
| Number of replacement trees: 18 three-inch caliper trees | | | | | |
| *Condition of the removed trees was provided by Andrew Chubb, Chubb Tree Service | | | | | |

Appendix B – Trees removed in 2025 indicated on survey

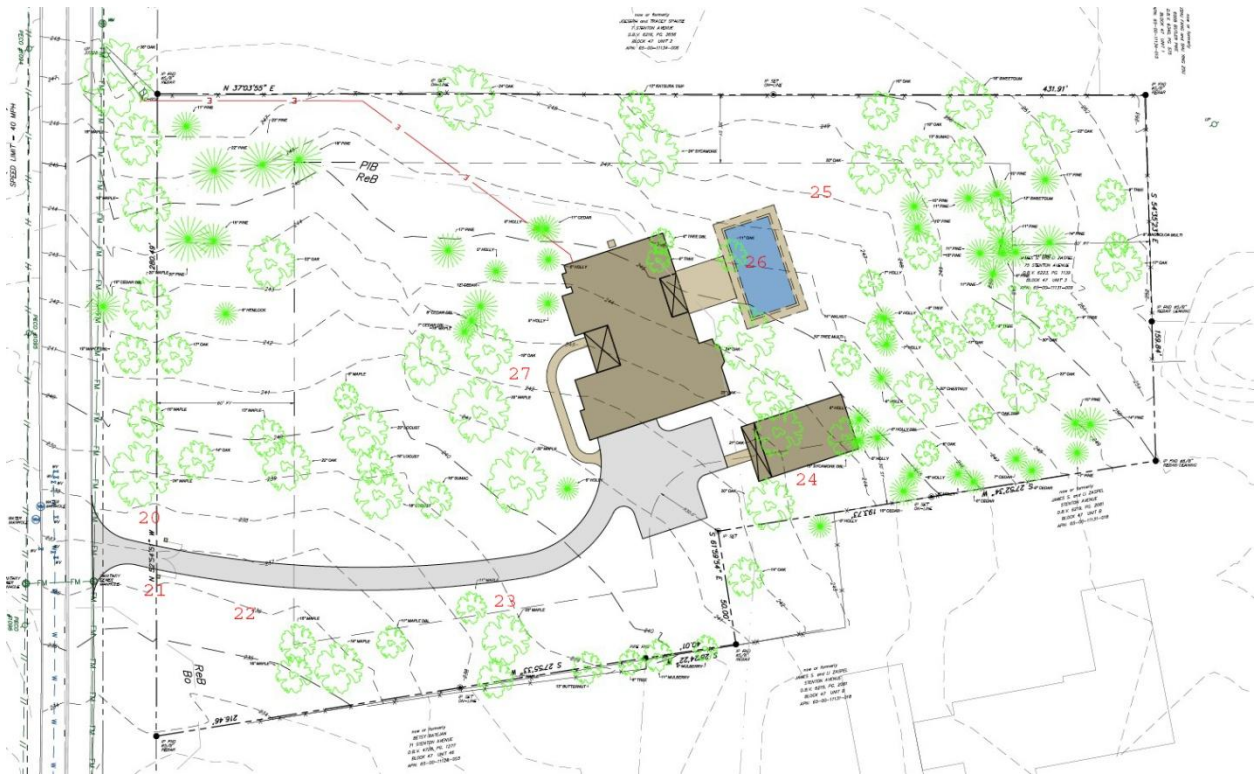

Appendix C – Trees proposed for removal spreadsheet

| File #793 | | | | | |
|--|-----------------------|------------------------------|--------------|--|---------------------------------|
| 14-Jan-26 | | | | | |
| 75 Stenton Ave, Plymouth Meeting PA 19462 | | | | | |
| Tree Inventory | | | | | |
| Tree# | Species (common name) | Latin | DBH (inches) | Condition | Replacement |
| 1 | Red maple | <i>Acer rubrum</i> | 12.5 | broken central lead, dead branches, missing bark | NO |
| 2 | Red maple | <i>Acer rubrum</i> | 24.5 | decay, cavities, sprouts, rotted roots | NO |
| 3 | Butternut | <i>Juglans cinerea</i> | 15 | borer (and woodpecker) damage, dead branches, trunk cracks | NO |
| 4 | Box elder | <i>Acer negundo</i> | 5 | dead | NO |
| 5 | Red mulberry | <i>Morus rubra</i> | 11 | decay, dead roots, girdling roots, dead branches, codominant | NO |
| 6 | Water oak | <i>Quercus nigra</i> | 22 | one dead branch | RETAIN - FUTURE REPLACEMENT YES |
| 7 | Willow oak | <i>Quercus phellos</i> | 23.5 | | RETAIN - FUTURE REPLACEMENT YES |
| 8 | Water oak | <i>Quercus nigra</i> | 25 | | RETAIN - FUTURE REPLACEMENT YES |
| 9 | Pin oak | <i>Quercus palustris</i> | 31 | most canopy is dead | NO |
| 10 | Pin oak | <i>Quercus palustris</i> | 13 | dieback, girdling root | NO |
| 11 | Common buckthorn | <i>Rhamnus cathartica</i> | 5+5.2 | | NO |
| 12 | Common buckthorn | <i>Rhamnus cathartica</i> | 6 | | YES |
| 13 | American sycamore | <i>Platanus occidentalis</i> | 23 | | RETAIN - FUTURE REPLACEMENT YES |
| 14 | Eastern red cedar | <i>Juniperus virginiana</i> | 13 | dead branches, thin canopy | NO |
| 15 | American holly | <i>Ilex opaca</i> | 6 | top of the tree is broken off, dead branches, thin canopy | NO |
| 16 | American sycamore | <i>Platanus occidentalis</i> | 17+18 | | RETAIN - FUTURE REPLACEMENT YES |
| 17 | American holly | <i>Ilex opaca</i> | 5.8+5.8 | | RETAIN - FUTURE REPLACEMENT YES |
| 18 | American holly | <i>Ilex opaca</i> | 4+4+6.5 | lean, dead branches, decay, fused branches | NO |
| 19 | Amur honeysuckle | <i>Lonicera maackii</i> | 5,5+9+6+3+3 | dead | NO |
| * Tree #13, American sycamore - client prefers to preserve the tree, if it is determined during construction that it is not possible, tree will be removed | | | | | |
| *Trees #6, 7, 8, 16 and #17 are to be retained until pool and woodshop construction begins (postponed for now) | | | | | |
| Total trees to be replaced: 1 | | | | | |
| Total diameter: 6 | | | | | |
| Number of replacement trees: 2 three-inch caliper trees | | | | | |

Appendix D – Trees proposed for removal indicated on survey



Appendix E – Survey indicating tree numbers



Appendix F – Survey – Pool and Wood Shop Removed

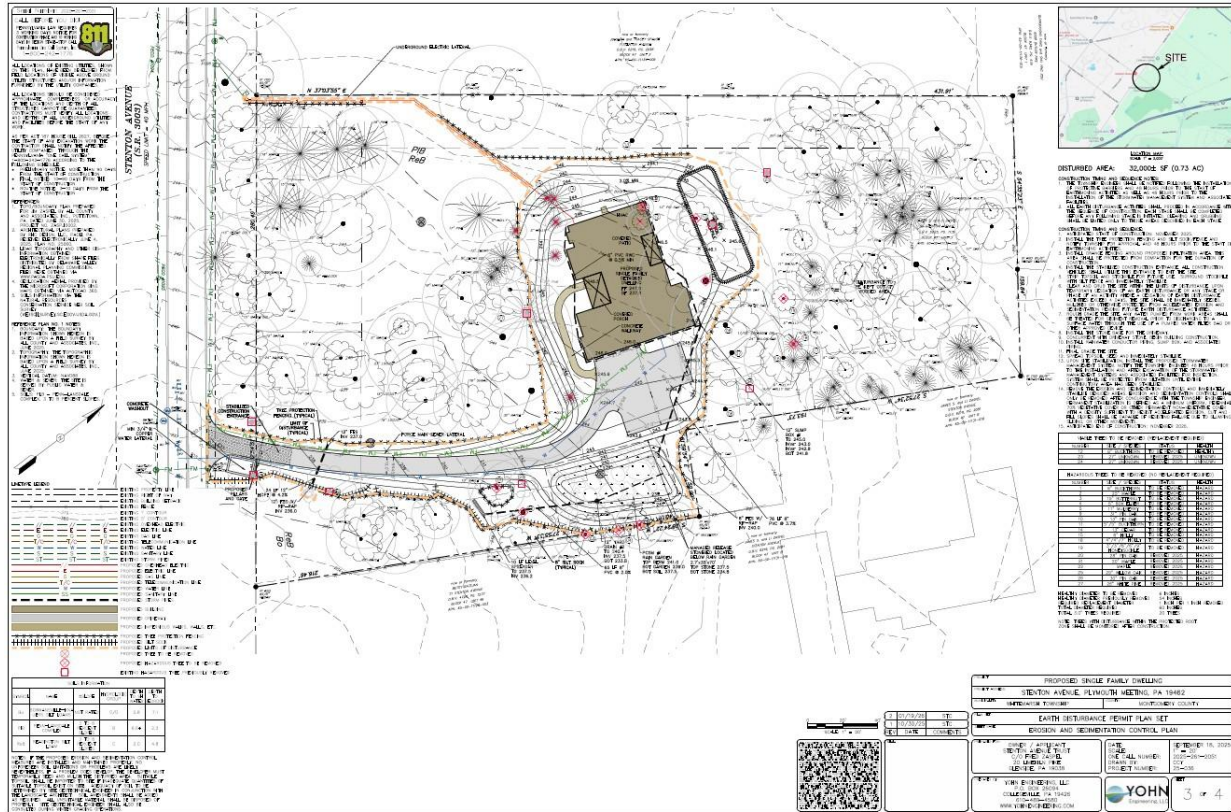

Appendix G – Photos

Trees removed in 2025

- Numbers in photos don't correlate with numbers in spreadsheet

Tree # 20



Tree #21



Tree #22



Tree #23



Tree #24



Tree #25



Tree #26



Tree #27



Trees proposed for removal

- Numbers in photos correspond with Tree# in spreadsheet







Appendix H - Assumptions and Limiting Conditions

1. Loss or alteration(s) of any parts of this report shall invalidate the entire report.
2. This report or a copy thereof does not imply right of publication (advertising, news or other media) by any other person other than to whom it is addressed without prior written consent of the consultant.
3. Any information obtained is assumed to be from reliable sources and has been verified insofar as possible for accuracy. However, the consultant cannot guarantee nor be responsible for accuracy of information provided by others.
4. Opinions and values expressed in this report represent the opinion of the consultant.
5. Plans, photographs and maps in this report are not necessarily to scale and shall be intended to use as visual aids and not be construed as architectural or engineering reports or surveys.
6. Information detailed in this report reflects only the items that were examined at the time of inspection.
7. The consultant does not have any financial or business associations with other commercial arborists therefore any future work performed by a commercial arborist shall be done via separate contract between the arborist and the client.
8. The consultant shall not be required to attend court and/or give testimony unless further contractual arrangements are made including payment of any additional fees for such services.

Appendix I - Certificate of Performance

I, Monika Buczko, certify that:

- I have personally inspected the subject tree(s) and/or the property referred to in this report and have stated my findings accurately;
- I have no current or prospective interest in the tree(s) or the property addressed in this report and have no personal interest or bias with respect to the parties involved;
- Any opinions, analysis and conclusions stated in this report are my own and are based on current scientific facts and procedures;
- My analysis, opinion and conclusions stated in this report have been prepared according to commonly accepted arboricultural practices;
- My compensation for this report is not contingent upon a predetermined conclusion that favors the client or any other party, nor upon the results of assessment;
- No one provided any professional assistance to me except as indicated within report.

I further certify that I am a member in good standing of ASCA (American Society of Consulting Arborists) and the ISA (International Society of Arboriculture). I have been involved in the field of Arboriculture since 2007.

Monika Buczko

January 16, 2025

Serial Number: 2025-261-2051
CALL BEFORE YOU DIG!
 PENNSYLVANIA LAW REQUIRES
**3 WORKING DAYS NOTICE FOR
 CONSTRUCTION PHASE AND 10 WORKING
 DAYS IN DESIGN STAGE-STOP CALL**
 Pennsylvania One Call System, Inc.
 1-800-242-1776

ALL LOCATIONS OF EXISTING UTILITIES, SHOWN
 ON THIS PLAN, HAVE BEEN DEVELOPED FROM
 FIELD LOCATIONS OF VISIBLE ABOVE GROUND
 UTILITY STRUCTURES AND/OR INFORMATION
 FURNISHED BY THE UTILITY COMPANIES.

ALL LOCATIONS SHOULD BE CONSIDERED
 APPROXIMATE. COMPLETENESS OR ACCURACY
 OF THE LOCATIONS AND DEPTH OF ALL
 STRUCTURES CANNOT BE GUARANTEED.
 CONTRACTORS MUST VERIFY ALL LOCATIONS
 AND DEPTHS OF ALL UNDERGROUND UTILITIES
 AND FACILITIES BEFORE THE START OF ANY
 WORK.

AS PER ACT 187 HOUSE BILL 2627, BEFORE
 THE START OF ANY EXCAVATION WORK THE
 CONTRACTOR SHALL NOTIFY THE AFFECTED
 UTILITY COMPANIES THROUGH THE
 PENNSYLVANIA "ONE CALL SYSTEM"
 1-800-242-1776 ACCORDING TO THE
 FOLLOWING SCHEDULES:
 • PRELIMINARY NOTICE: MORE THAN 90 DAYS
 FROM THE START OF CONSTRUCTION
 • FINAL NOTICE: 10-30 DAYS FROM THE
 START OF CONSTRUCTION
 • ROUTINE NOTICE: 3-10 DAYS FROM THE
 START OF CONSTRUCTION

- REFERENCES:**
1. TOPO/BOUNDARY PLAN PREPARED FOR JIM ZASPEL BY ALL COUNTY AND ASSOCIATES, INC., POTTSTOWN, PA. DATED JUNE 30, 2025. PROJECT NO. ZASPJ002.
 2. ARCHITECTURAL PLANS PREPARED BY RHC DESIGN, LLC., PAOLI, PA. RECEIVED ELECTRONICALLY JUNE 4, 2025. PLAN NO. 25050.
 3. LIDAR TOPOGRAPHY AND OTHER GIS INFORMATION OBTAINED ELECTRONICALLY FROM SHAPE FILES DISTRIBUTED BY DELAWARE VALLEY REGIONAL PLANNING COMMISSION. FILES WERE OBTAINED VIA WWW.PASDA.PSU.EDU.
 4. GEOLOGICAL AERIAL PROVIDED BY THE MICROSOFT CORPORATION BING MAPS OBTAINED VIA AUTOCAD 360.
 5. SOILS INFORMATION VIA THE NATURAL RESOURCES CONSERVATION SERVICE WEB SOIL SURVEY (WEBSOILSURVEY.SC.EGOV.USDA.GOV.)

- REFERENCE PLAN NO. 1 NOTES:**
1. BOUNDARY: THE BOUNDARY INFORMATION SHOWN HEREON IS BASED UPON A FIELD SURVEY BY ALL COUNTY AND ASSOCIATES, INC., JUNE 2025.
 2. TOPOGRAPHY: THE TOPOGRAPHIC INFORMATION SHOWN HEREON IS BASED UPON A FIELD SURVEY BY ALL COUNTY AND ASSOCIATES, INC., JUNE 2025.
 3. VERTICAL DATUM: NAVD83
 4. WATER & SEWER: THE SITE IS SERVED BY PUBLIC WATER & SEWER.
 5. SOILS: PLB - PENN-LANSDALE COMPLEX, 3 TO 8 PERCENT SLOPES.

LINE/TYPE LEGEND

| | |
|-------|--|
| --- | EXISTING PROPERTY LINE |
| - - - | EXISTING RIGHT OF WAY |
| - - - | EXISTING BUILDING SETBACK |
| - - - | EXISTING FENCE |
| - - - | EXISTING 1' CONTOUR |
| - - - | EXISTING 5' CONTOUR |
| - - - | EXISTING OVERHEAD ELECTRIC |
| - - - | EXISTING ELECTRIC LINE |
| - - - | EXISTING GAS LINE |
| - - - | EXISTING TELECOMMUNICATION LINE |
| - - - | EXISTING WATER LINE |
| - - - | EXISTING SANITARY LINE |
| - - - | EXISTING STORM PIPES |
| - - - | PROPOSED OVERHEAD ELECTRIC |
| - - - | PROPOSED ELECTRIC LINE |
| - - - | PROPOSED GAS LINE |
| - - - | PROPOSED TELECOMMUNICATION LINE |
| - - - | PROPOSED WATER LINE |
| - - - | PROPOSED SANITARY LINE |
| - - - | PROPOSED STORM PIPES |
| - - - | PROPOSED BUILDING |
| - - - | PROPOSED DRIVEWAY |
| - - - | PROPOSED IMPERVIOUS WALKS, WALLS, ETC. |

SOILS INFORMATION

| SYMBOL | NAME | %SLOPE | HYDROLOGIC GROUP | DEPTH TO SH WATER | DEPTH TO SH BEDROCK |
|--------|---------------------------------|-----------------------|------------------|-------------------|---------------------|
| Bo | BOWMANSVILLE-KNAUERS SILT LOAMS | NOT RATED | C/D | 0.8 | 7.1 |
| PIB | PENN-LANSDALE COMPLEX | 3 TO 8 PERCENT SLOPES | B | 6.6+ | 2.3 |
| ReB | READINGTON SILT LOAM | 3 TO 8 PERCENT SLOPES | C | 2.0 | 4.8 |

NOTES: IF THE PROPOSED EROSION AND SEDIMENTATION CONTROL MEASURES ARE INSTALLED AND MAINTAINED PROPERLY, NO UNFORESEEN SOIL LIMITATIONS OR PROBLEMS ARE LIKELY. NEVERTHELESS, IF A PROBLEM DOES DEVELOP, THE DEVELOPER MUST TEMPORARILY SEED AND MULCH THE DISTURBED AREA. SUITABLE TOPSOIL SHALL BE IMPORTED TO SITE IF INADEQUATE QUANTITIES OF SUITABLE TOPSOIL EXIST ON SITE. ADEQUACY OF SOIL TO BE DETERMINED BY SITE GEOTECHNICAL ENGINEER IN CONJUNCTION WITH THE LANDSCAPE ARCHITECT. SOIL AMENDMENTS SHALL BE ADDED AS REQUIRED. ALL UNSUITABLE MATERIAL SHALL BE DISPOSED OF PROPERLY. SITE GEOTECHNICAL ENGINEER SHALL ALSO BE CONSULTED DURING WINTER GRADING OPERATIONS.

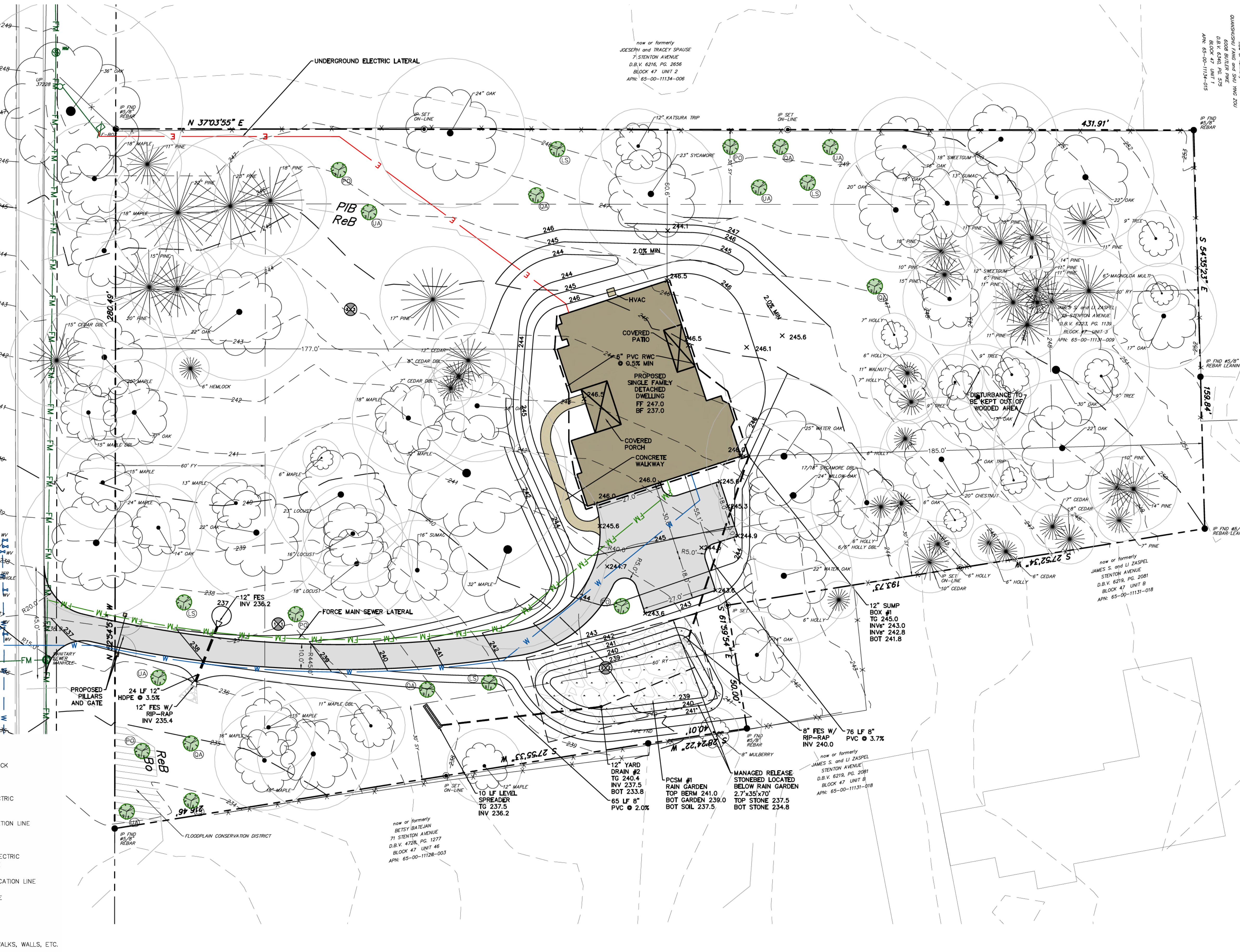

PROPOSED REPLACEMENT TREES

| Symbol | Quantity | Common Name | Scientific Name | Size |
|--------|----------|-------------------|-------------------------|-----------|
| PO | 5 | AMERICAN SYCAMORE | PLANTUS OCCIDENTALIS | 3.0" CAL. |
| UA | 5 | AMERICAN ELM | ULMUS AMERICANA | 3.0" CAL. |
| QA | 5 | WHITE OAK | QUERCUS ALBA | 3.0" CAL. |
| LS | 5 | AMERICAN SWEETGUM | LIQUIDAMBAR STYRACIFLUA | 3.0" CAL. |

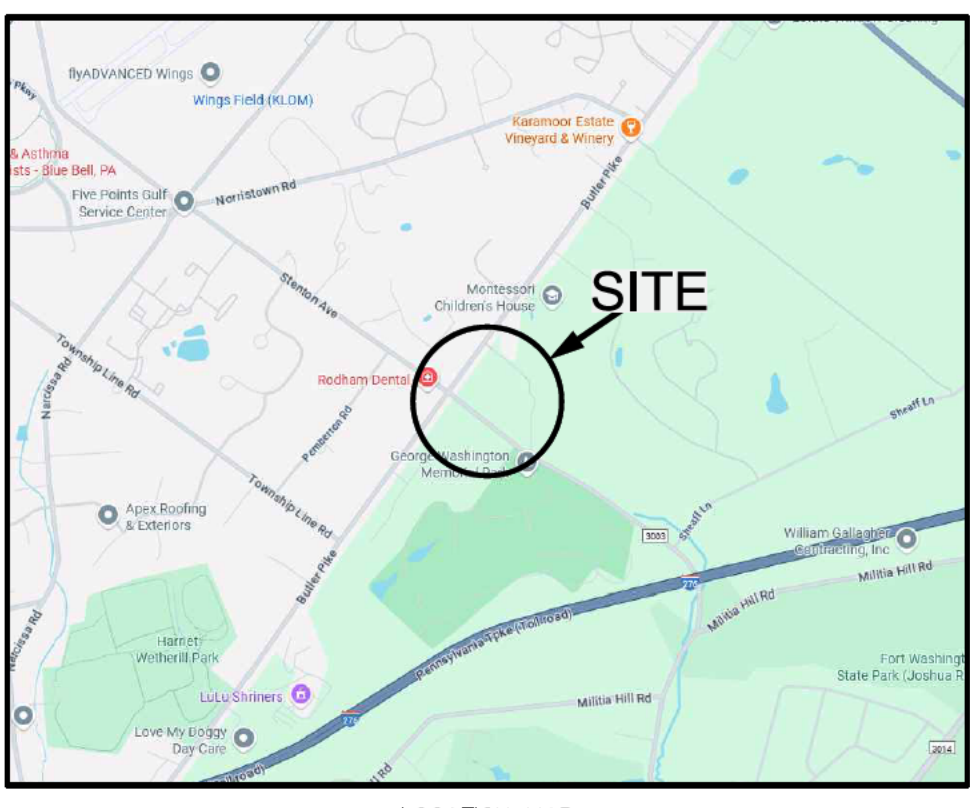

ZONING DATA AAA: (SINGLE FAMILY DISTRICT):

| REQUIRED | PROPOSED |
|-------------------------------------|-----------|
| MINIMUM LOT AREA | 43,560 SF |
| MINIMUM LOT WIDTH (Ø BUILDING LINE) | 175 FT |
| MINIMUM FRONT YARD | 270.8 FT |
| MINIMUM SIDE YARD EACH | 60 FT |
| MINIMUM SIDE YARD AGGREGATE | 30 FT |
| MINIMUM REAR YARD | 60 FT |
| MINIMUM BUILDING HEIGHT | 60 FT |
| MAXIMUM BUILDING COVERAGE | 35 FT |
| | 15% |
| | 8.7% |

FOR MORE DETAILED INFORMATION REFER TO THE ZONING CODE OF WHITEMARSH TOWNSHIP, LATEST EDITION.

EXISTING LOT DATA:

| RECORD OWNER: | STENTON AVENUE TRUST |
|----------------------|-----------------------|
| DEED BOOK & PAGE NO. | 20 LIMEKILN PIKE |
| PARCEL ID: | GLENSIDE, PA 19038 |
| TAX MAP ID: | 6223-1135 |
| GROSS LOT AREA: | 65-00-11131-00-9 |
| EXISTING IMPERVIOUS: | 65047-032 |
| | 97,322 SF (2.2342 AC) |
| | 0 SF (0.0%) |

PROPOSED IMPERVIOUS COVERAGE:

| BUILDING | 4,077 SF (4.2%) |
|--------------------|-------------------|
| DRIVEWAY | 4,100 SF |
| WALKS, WALKS, ETC. | 296 SF |
| TOTAL | 8,473 SF (8.7%) |
| NET INCREASE | 8,473 SF (8.7%) |
| MAXIMUM ALLOWED | 14,598 SF (15.0%) |

- GENERAL NOTES:**
1. THE INTENT OF THIS PLAN IS TO ILLUSTRATE THE CONSTRUCTION OF A SINGLE FAMILY DWELLING AND ASSOCIATED IMPROVEMENTS.
 2. THE STORMWATER MANAGEMENT FACILITIES HAVE BEEN DESIGNED FOR THE PROPOSED IMPERVIOUS (8,473 SF), IMPERVIOUS WITHIN THE ROW (341 SF), AND FUTURE IMPERVIOUS (3,380 SF) OF WHICH A PORTION MAY GO UNCONTROLLED (1,913 SF).
 3. STORMWATER FACILITIES SHALL BE OWNED AND MAINTAINED BY THE PROPERTY OWNER IN PERPETUITY. THE PROPERTY OWNER SHALL PROVIDE A BLANKET STORMWATER ACCESS EASEMENT TO THE TOWNSHIP FOR THE PURPOSE OF ACCESS TO THE STORMWATER FACILITIES. IF, IN THE JUDGMENT OF THE TOWNSHIP ENGINEER, THE OWNER HAS FAILED TO MAINTAIN THE STORMWATER FACILITIES IN SUCH A MANNER AS TO ENSURE THEIR PROPER FUNCTIONING, THE TOWNSHIP AFTER PROVIDING A WRITTEN NOTICE, SHALL HAVE THE RIGHT TO ENTER UPON THE LANDS OF THE OWNER AND TO MAKE ANY REPAIRS AS MAY BE NECESSARY TO THE STORMWATER FACILITIES TO ENSURE THAT SUCH FACILITIES FUNCTION AND PERFORM IN ACCORDANCE WITH THE DESIGN SPECIFICATIONS. ANY AND ALL COSTS INCURRED BY THE TOWNSHIP FOR SUCH REPAIRS AND/OR MAINTENANCE SHALL BE PAID IN FULL BY THE OWNER. A LIEN OR LIENS MAY BE PLACED AGAINST THE PROPERTY IF THE OWNER FAILS TO REMIT PAYMENT WITHIN SIXTY (60) DAYS.
 4. NEWLY GRADED SLOPES OF OVER TWENTY-FIVE (25%) PERCENT MUST BE STABILIZED WITH SOD OR JUTE NETTING AND SEED.

I CERTIFY THAT THE PROPERTY WAS ANALYZED FOR KARST FEATURES VIA "MAP 88-DENSITY OF MAPPED KARST FEATURES IN SOUTH-CENTRAL AND SOUTHEASTERN PENNSYLVANIA" BY WILLIAM E. KOCHANOV AND STUART O. REESE DATED 2003, AND THERE WERE NONE FOUND WITHIN 1/2 MILE OF THE SITE AND THAT THE PROPERTY WAS ANALYZED FOR LIMESTONE VIA "GEOLOGIC MAP OF PENNSYLVANIA" PREPARED BY THE COMMONWEALTH OF PENNSYLVANIA DEPARTMENT OF ENVIRONMENTAL RESOURCES DATED 1980 AND THE SITE WAS FOUND TO BE LOCATED IN THE TRIASSIC STOCKTON FORMATION WHICH IS PRIMARILY SANDSTONE, MUDSTONE, AND SHALE.

Christopher C. Yohn, P.E. 01/19/26 DATE

CHRISTOPHER C. YOHN, P.E., HAS REVIEWED AND HEREBY CERTIFIES THAT THE STORMWATER MANAGEMENT SITE PLAN MEETS ALL DESIGN STANDARDS AND CRITERIA OF CHAPTER 58, "GRADING, EROSION CONTROL, STORMWATER MANAGEMENT AND BEST MANAGEMENT PRACTICES".

Christopher C. Yohn, P.E.

PROPOSED SINGLE FAMILY DWELLING

| | |
|------------------|--|
| PROJECT ADDRESS: | STENTON AVENUE, PLYMOUTH MEETING, PA 19462 |
| MUNICIPALITY: | WHITEMARSH TOWNSHIP |
| COUNTY: | MONTGOMERY COUNTY |

EARTH DISTURBANCE PERMIT PLAN SET

| | |
|-------------|--|
| PLAN SET: | EARTH DISTURBANCE PERMIT PLAN SET |
| SHEET NAME: | POST CONSTRUCTION STORMWATER MANAGEMENT PLAN |

OWNER / APPLICANT

| | |
|-------------------|----------------------|
| OWNER / APPLICANT | STENTON AVENUE TRUST |
| C/O | FRED ZASPEL |
| 20 LIMEKILN PIKE | GLENSIDE, PA 19038 |

YOHN ENGINEERING, LLC

| | |
|----------------|--------------------------|
| PREPARED BY: | YOHN ENGINEERING, LLC |
| P.O. BOX 26094 | COLLEGEVILLE, PA 19426 |
| 610-489-4580 | WWW.YOHNEENGINEERING.COM |

| REV | DATE | COMMENTS |
|-----|----------|----------|
| 2 | 01/19/26 | STC |
| 1 | 10/30/25 | STC |

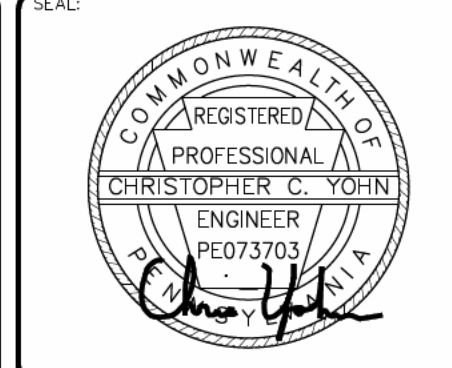

ALL DOCUMENTS PREPARED OR FINANCED BY ENGINEER AND PROPERTY INTEREST INCLUDE THE COPYRIGHT AND THE RIGHT OF REUSE IN THEIR ENTIRETY. ANY REUSE OR REPRODUCTION OF ANY PART OF THIS DOCUMENT WITHOUT THE WRITTEN PERMISSION OF THE ENGINEER OR PROPERTY OWNER IS STRICTLY PROHIBITED. THE ENGINEER AND PROPERTY OWNER SHALL BE RESPONSIBLE FOR THE ACCURACY AND COMPLETENESS OF THE INFORMATION PROVIDED TO THE ENGINEER AND PROPERTY OWNER. THE ENGINEER AND PROPERTY OWNER SHALL BE RESPONSIBLE FOR THE ACCURACY AND COMPLETENESS OF THE INFORMATION PROVIDED TO THE ENGINEER AND PROPERTY OWNER. THE ENGINEER AND PROPERTY OWNER SHALL BE RESPONSIBLE FOR THE ACCURACY AND COMPLETENESS OF THE INFORMATION PROVIDED TO THE ENGINEER AND PROPERTY OWNER.

Serial Number: 2025-261-2051
CALL BEFORE YOU DIG!
 PENNSYLVANIA LAW REQUIRES
**3 WORKING DAYS NOTICE FOR
 CONSTRUCTION PHASE AND 10 WORKING
 DAYS IN DESIGN STAGE-STOP CALL**
 Pennsylvania One Call System, Inc.
 1-800-242-1776

ALL LOCATIONS OF EXISTING UTILITIES, SHOWN ON THIS PLAN, HAVE BEEN DEVELOPED FROM FIELD LOCATIONS OF VISIBLE ABOVE GROUND UTILITY STRUCTURES AND/OR INFORMATION FURNISHED BY THE UTILITY COMPANIES.

ALL LOCATIONS SHOULD BE CONSIDERED APPROXIMATE. COMPLETENESS OR ACCURACY OF THE LOCATIONS AND DEPTH OF ALL STRUCTURES CANNOT BE GUARANTEED. CONTRACTORS SHALL VERIFY ALL LOCATIONS AND DEPTHS OF ALL UNDERGROUND UTILITIES AND FACILITIES BEFORE THE START OF ANY WORK.

AS PER ACT 187 HOUSE BILL 2627, BEFORE THE START OF ANY EXCAVATION WORK THE CONTRACTOR SHALL NOTIFY THE AFFECTED UTILITY COMPANIES THROUGH THE PENNSYLVANIA "ONE CALL SYSTEM" 1-800-242-1776 ACCORDING TO THE FOLLOWING SCHEDULES:
 • PRELIMINARY NOTICE: MORE THAN 90 DAYS FROM THE START OF CONSTRUCTION
 • FINAL NOTICE: 10-90 DAYS FROM THE START OF CONSTRUCTION
 • ROUTINE NOTICE: 3-10 DAYS FROM THE START OF CONSTRUCTION

- REFERENCES:**
1. TOPO/BOUNDARY PLAN PREPARED FOR JAMES S. AND LI ZASPEL AND ASSOCIATES, INC., POTTSTOWN, PA. DATED JUNE 30, 2025. PROJECT NO. ZASPEL002.
 2. ARCHITECTURAL PLANS PREPARED BY RHC DESIGN, LLC, PAOLI, PA. RECEIVED ELECTRONICALLY JUNE 4, 2025. PLAN NO. 25060.
 3. LIDAR TOPOGRAPHY AND OTHER GIS INFORMATION OBTAINED ELECTRONICALLY FROM SHAPE FILES DISTRIBUTED BY DELAWARE VALLEY REGIONAL PLANNING COMMISSION. FILES WERE OBTAINED VIA WWW.PASDA.PSU.EDU.
 4. GEOLOCATION AERIAL PROVIDED BY THE MICROSOFT CORPORATION BING MAPS OBTAINED VIA AUTOCAD 360.
 5. SOILS INFORMATION VIA THE NATURAL RESOURCES CONSERVATION SERVICE WEB SOIL SURVEY (WEBSOILSURVEY.SC.EGOV.USDA.GOV.)

- REFERENCE PLAN NO. 1 NOTES:**
1. BOUNDARY: THE BOUNDARY INFORMATION SHOWN HEREON IS BASED UPON A FIELD SURVEY BY ALL COUNTY AND ASSOCIATES, INC., JUNE 2025.
 2. TOPOGRAPHY: THE TOPOGRAPHIC INFORMATION SHOWN HEREON IS BASED UPON A FIELD SURVEY BY ALL COUNTY AND ASSOCIATES, INC., JUNE 2025.
 3. VERTICAL DATUM: NAVD83
 4. WATER & SEWER: THE SITE IS SERVED BY PUBLIC WATER & SEWER.
 5. SOILS: PLB - PENN-LANSDALE COMPLEX, 3 TO 8 PERCENT SLOPES.

LINE TYPE LEGEND

| | |
|-------|--|
| --- | EXISTING PROPERTY LINE |
| - - - | EXISTING RIGHT OF WAY |
| - - - | EXISTING BUILDING SETBACK |
| - - - | EXISTING FENCE |
| - - - | EXISTING 1' CONTOUR |
| - - - | EXISTING 5' CONTOUR |
| - - - | EXISTING OVERHEAD ELECTRIC |
| - - - | EXISTING ELECTRIC LINE |
| - - - | EXISTING GAS LINE |
| - - - | EXISTING TELECOMMUNICATION LINE |
| - - - | EXISTING WATER LINE |
| - - - | EXISTING SANITARY LINE |
| - - - | EXISTING STORM PIPES |
| - - - | PROPOSED OVERHEAD ELECTRIC |
| - - - | PROPOSED ELECTRIC LINE |
| - - - | PROPOSED GAS LINE |
| - - - | PROPOSED TELECOMMUNICATION LINE |
| - - - | PROPOSED WATER LINE |
| - - - | PROPOSED SANITARY LINE |
| - - - | PROPOSED STORM PIPES |
| - - - | PROPOSED BUILDING |
| - - - | PROPOSED DRIVEWAY |
| - - - | PROPOSED IMPERVIOUS WALKS, WALLS, ETC. |
| - - - | PROPOSED TREE PROTECTION FENCING |
| - - - | PROPOSED SILT SOCK |
| - - - | PROPOSED LIMITS OF DISTURBANCE |
| - - - | PROPOSED TREE TO BE REMOVED |
| - - - | PROPOSED HAZARDOUS TREE TO BE REMOVED |
| - - - | EXISTING HAZARDOUS TREE PREVIOUSLY REMOVED |

SOILS INFORMATION

| SYMBOL | NAME | %SLOPE | HYDROLOGIC GROUP | DEPTH TO SH WATER | DEPTH TO BEDROCK |
|--------|---------------------------------|-----------------------|------------------|-------------------|------------------|
| Bo | BOWMANSVILLE-KNAUERS SILT LOAMS | NOT RATED | C/D | 0.8 | 7.1 |
| PIB | PENN-LANSDALE COMPLEX | 3 TO 8 PERCENT SLOPES | B | 6.6+ | 2.3 |
| ReB | READINGTON SILT LOAM | 3 TO 8 PERCENT SLOPES | C | 2.0 | 4.8 |

NOTES: IF THE PROPOSED EROSION AND SEDIMENTATION CONTROL MEASURES ARE INSTALLED AND MAINTAINED PROPERLY, NO UNFORESEEN SOIL LIMITATIONS OR PROBLEMS ARE LIKELY. NEVERTHELESS, IF A PROBLEM DOES DEVELOP, THE DEVELOPER MUST TEMPORARILY SEED AND MULCH THE DISTURBED AREA. SUITABLE TOPSOIL SHALL BE IMPORTED TO SITE IF INADEQUATE QUANTITIES OF SUITABLE TOPSOIL EXIST ON SITE. ADEQUACY OF SOIL TO BE DETERMINED BY SITE GEOTECHNICAL ENGINEER IN CONJUNCTION WITH THE LANDSCAPE ARCHITECT. SOIL AMENDMENTS SHALL BE ADDED AS REQUIRED. ALL UNSUITABLE MATERIAL SHALL BE DISPOSED OF PROPERLY. SITE GEOTECHNICAL ENGINEER SHALL ALSO BE CONSULTED DURING WINTER GRADING OPERATIONS.

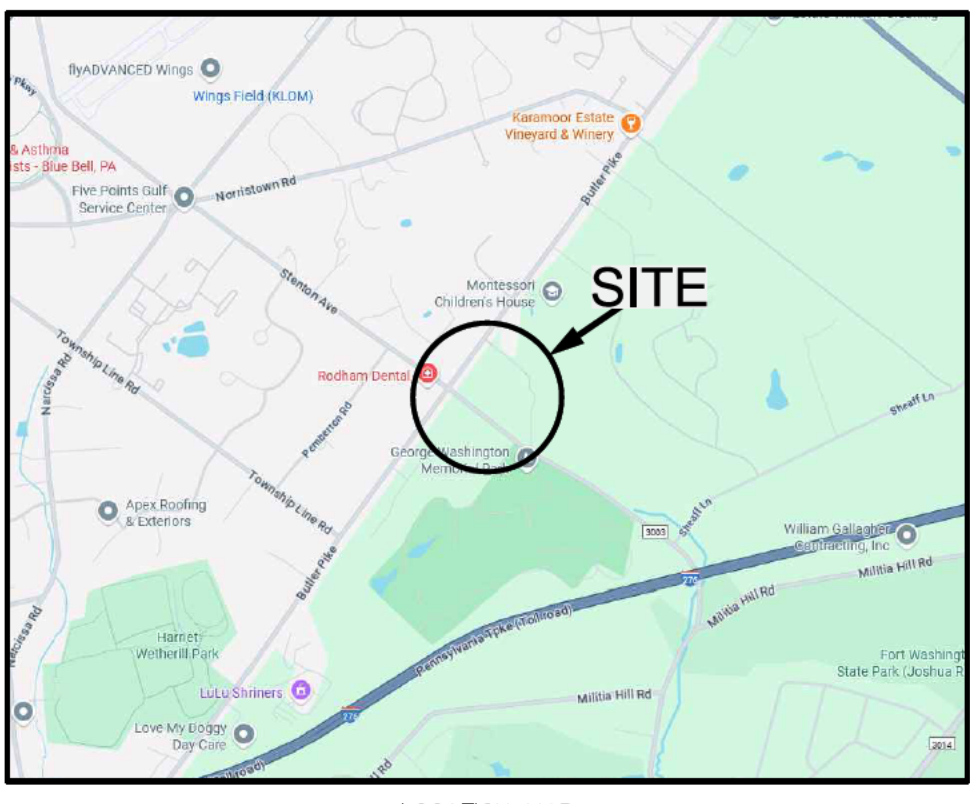
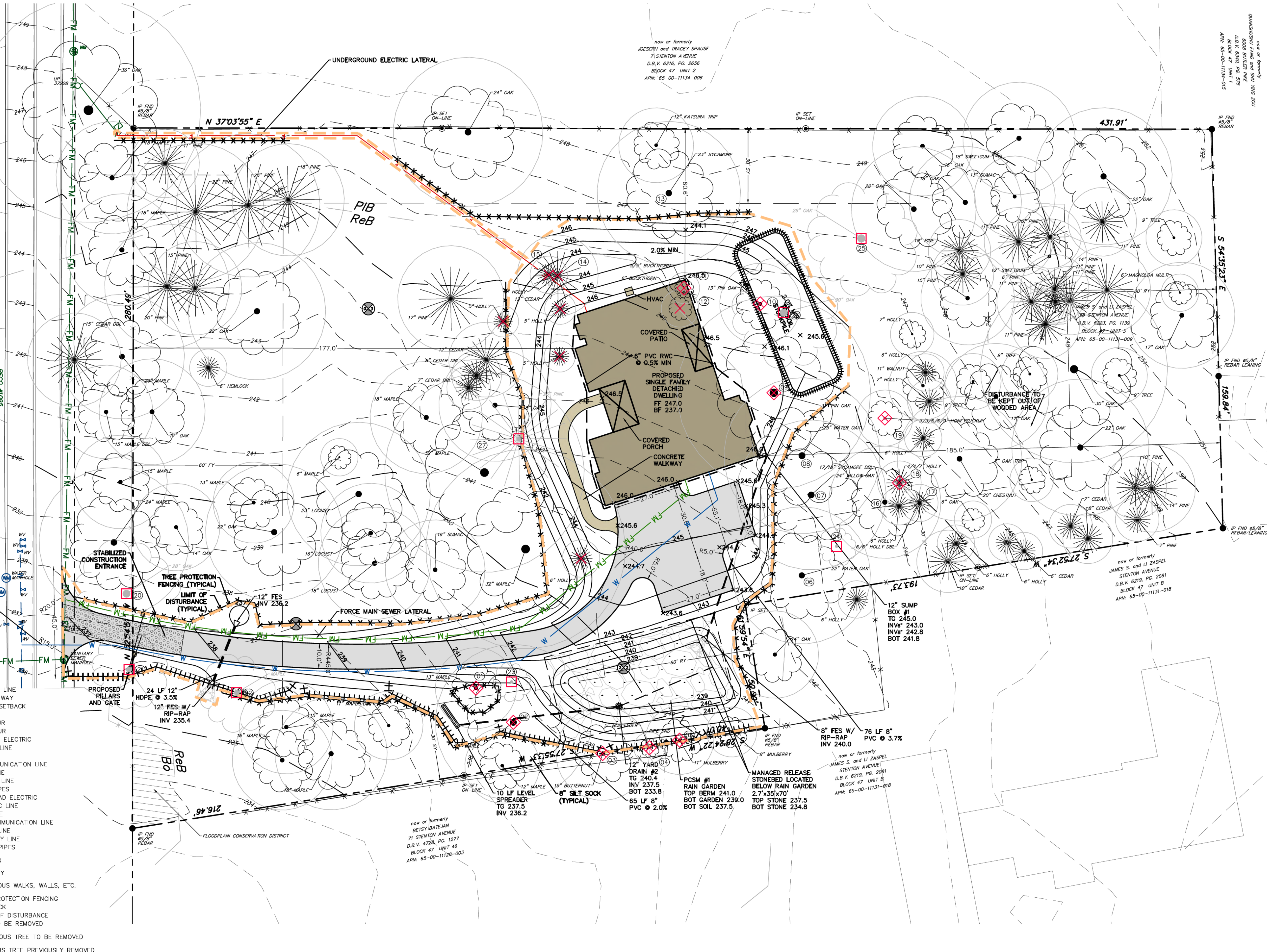

LOCATION MAP
 SCALE: 1" = 2000'

- DISTURBED AREA: 32,000± SF (0.73 AC)**
- CONSTRUCTION TIMING AND SEQUENCE NOTES:**
1. THE PERMIT HOLDER SHALL NOTIFY THE TOWNSHIP ENGINEER IN ORDER TO OBTAIN INSPECTIONS AT LEAST 48 HOURS BEFORE THE INSPECTION IS TO BE MADE FOR: INITIAL INSPECTION, ROUGH GRADING, DRAINAGE FACILITIES, BMPs, SPECIAL STRUCTURES AND FINAL INSPECTION.
 2. ALL EARTH DISTURBANCE ACTIVITIES SHALL PROCEED IN ACCORDANCE WITH THE SEQUENCE OF CONSTRUCTION. EACH STAGE SHALL BE COMPLETED BEFORE ANY FOLLOWING STAGE IS INITIATED. CLEARING AND GRUBBING SHALL BE LIMITED TO THOSE AREAS DESCRIBED IN EACH STAGE.
 3. PLANS FOR THE EARTH DISTURBANCE ACTIVITY, BEARING THE STAMP OF APPROVAL OF THE TOWNSHIP ENGINEER, SHALL BE MAINTAINED AT THE SITE DURING THE PROCESS OF THE GRADING WORK AND UNTIL THE WORK HAS BEEN COMPLETED.

- CONSTRUCTION TIMING AND SEQUENCE:**
1. ANTICIPATED START OF CONSTRUCTION: NOVEMBER 2025.
 2. INSTALL THE TREE PROTECTION FENCING AND SILT SOCK FENCE AND NOTIFY TOWNSHIP FOR APPROVAL AND 48 HOURS PRIOR TO THE START OF EARTHMOVING ACTIVITIES. A PRE-CONSTRUCTION CONFERENCE WITH THE SHADE TREE COMMISSION'S DESIGNEE IS REQUIRED PRIOR TO THE START OF CONSTRUCTION.
 3. INSTALL ORANGE FENCING AROUND PROPOSED INFILTRATION AREA. THIS AREA SHALL BE PROTECTED FROM COMPACTION FOR THE DURATION OF CONSTRUCTION.
 4. INSTALL THE STABILIZED CONSTRUCTION ENTRANCE. ALL CONSTRUCTION VEHICLES SHALL UTILIZE THIS ENTRANCE TO EXIT THE SITE.
 5. STRIP TOPSOIL AND STOCKPILE FOR FUTURE USE. SURROUND STOCKPILE WITH SILT FENCE AND IMMEDIATELY STABILIZE PERMANENT REMOVAL OF TOPSOIL FROM LAND WITHIN THE TOWNSHIP IS PROHIBITED.
 6. CLEAR AND GRUB THE SITE WITHIN THE LIMITS OF DISTURBANCE. UPON TEMPORARY CESSATION OF AN EARTH DISTURBANCE OR ANY STAGE OR PHASE OF AN ACTIVITY WHERE A CESSATION OF EARTH DISTURBANCE ACTIVITIES EXCEED 4 DAYS, THE SITE SHALL BE IMMEDIATELY SEED, MULCHED OR OTHERWISE PROTECTED FROM ACCELERATED EROSION AND SEDIMENTATION PENDING FUTURE EARTH DISTURBANCE ACTIVITIES.
 7. ROUGH GRADE THE SITE. ANY WATER PUMPED FROM WORK AREAS SHALL BE TREATED FOR SEDIMENT REMOVAL PRIOR TO DISCHARGING TO A SURFACE WATER THROUGH THE USE OF A PUMPED WATER FILTER BAG OR OTHER APPROVED DEVICE.
 8. INSTALL THE STONE BASE FOR THE DRIVEWAY.
 9. CONCURRENT WITH DRIVEWAY STONE, BEGIN BUILDING CONSTRUCTION.
 10. INSTALL RAINWATER CONDUCTOR PIPING, SUMP BOX, AND ASSOCIATED PIPING.
 11. FINAL GRADE THE SITE.
 12. SPREAD TOPSOIL, SEED, AND IMMEDIATELY STABILIZE.
 13. UPON SITE STABILIZATION, INSTALL THE PROPOSED STORMWATER MANAGEMENT SYSTEM. NOTIFY THE TOWNSHIP ENGINEER 48 HOURS PRIOR TO THE INSTALLATION AND AFTER EXCAVATION OF THE STORMWATER MANAGEMENT SYSTEMS AND ASSOCIATED FACILITIES FOR INSPECTION. SYSTEM SHALL BE PROTECTED FROM SILTATION UNTIL ENTIRE CONTRIBUTORY AREA HAS BEEN STABILIZED.
 14. REMOVE THE EROSION AND SEDIMENTATION CONTROLS AND IMMEDIATELY STABILIZE DENuded AREAS. EROSION AND SEDIMENTATION CONTROLS SHALL NOT BE REMOVED AFTER CONSTRUCTION WITH THE TOWNSHIP ENGINEER. PERMANENT STABILIZATION IS DEFINED AS A MINIMUM UNIFORM, PERENNIAL FORK VEGETATIVE COVER OR OTHER PERMANENT NON-VEGETATIVE COVER WITH A DENSITY SUFFICIENT TO RESIST ACCELERATED EROSION. CUT AND FILL SLOPES SHALL BE CAPABLE OF RESISTING FAILURE DUE TO SLUMPING, SLIDING, OR OTHER MOVEMENTS.
 15. ANTICIPATED END OF CONSTRUCTION: NOVEMBER 2026.

VARIABLE TREES TO BE REMOVED (REPLACEMENT REQUIRED)

| NUMBER | SIZE / SPECIES | STATUS | HEALTH |
|--------|----------------|---------------|---------|
| 12 | 6" BUCKTHORN | TO BE REMOVED | HEALTHY |
| 23 | 27" UNKNOWN | REMOVED 2025 | UNKNOWN |
| 24 | 27" UNKNOWN | REMOVED 2025 | UNKNOWN |

HAZARDOUS TREES TO BE REMOVED (NO REPLACEMENT REQUIRED)

| NUMBER | SIZE / SPECIES | STATUS | HEALTH |
|--------|-----------------------------|---------------|--------|
| 2 | 6" BUCKTHORN | TO BE REMOVED | HAZARD |
| 2 | 25" MAPLE | TO BE REMOVED | HAZARD |
| 3 | 15" BUTTERNUT | TO BE REMOVED | HAZARD |
| 4 | 5" BOX ELDER | TO BE REMOVED | HAZARD |
| 5 | 11" MULBERRY | TO BE REMOVED | HAZARD |
| 9 | 31" PIN OAK | TO BE REMOVED | HAZARD |
| 10 | 13" PIN OAK | TO BE REMOVED | HAZARD |
| 11 | 5 1/2" BUCKTHORN | TO BE REMOVED | HAZARD |
| 14 | 13" CEDAR | TO BE REMOVED | HAZARD |
| 15 | 6" HOLLY | TO BE REMOVED | HAZARD |
| 18 | 4 1/4" 7 1/2" 9 1/2" 9 1/2" | TO BE REMOVED | HAZARD |
| 19 | 3 1/2" 7 1/2" 9 1/2" 9 1/2" | TO BE REMOVED | HAZARD |
| 20 | 28" PIN OAK | REMOVED 2025 | HAZARD |
| 21 | 20" MAPLE | REMOVED 2025 | HAZARD |
| 22 | MAPLE | REMOVED 2025 | HAZARD |
| 25 | 29" WILLOW OAK | REMOVED 2025 | HAZARD |
| 26 | 30" PIN OAK | REMOVED 2025 | HAZARD |
| 27 | 26" WHITE PINE | REMOVED 2025 | HAZARD |

HEALTHY DIAMETER TO BE REMOVED 6 INCHES
 HEALTHY DIAMETER PREVIOUSLY REMOVED 54 INCHES
 REQUIRED REPLACEMENT DIAMETER 1 INCH PER 1 INCH REMOVED
 TOTAL DIAMETER REQUIRED 60 INCHES
 TOTAL 3.0" TREES REQUIRED 20 TREES

NOTE: TREES WITH DISTURBANCE WITHIN THE PROTECTED ROOT ZONE SHALL BE MONITORED AFTER CONSTRUCTION.

SOILS INFORMATION

| SYMBOL | NAME | %SLOPE | HYDROLOGIC GROUP | DEPTH TO SH WATER | DEPTH TO BEDROCK |
|--------|---------------------------------|-----------------------|------------------|-------------------|------------------|
| Bo | BOWMANSVILLE-KNAUERS SILT LOAMS | NOT RATED | C/D | 0.8 | 7.1 |
| PIB | PENN-LANSDALE COMPLEX | 3 TO 8 PERCENT SLOPES | B | 6.6+ | 2.3 |
| ReB | READINGTON SILT LOAM | 3 TO 8 PERCENT SLOPES | C | 2.0 | 4.8 |

NOTES: IF THE PROPOSED EROSION AND SEDIMENTATION CONTROL MEASURES ARE INSTALLED AND MAINTAINED PROPERLY, NO UNFORESEEN SOIL LIMITATIONS OR PROBLEMS ARE LIKELY. NEVERTHELESS, IF A PROBLEM DOES DEVELOP, THE DEVELOPER MUST TEMPORARILY SEED AND MULCH THE DISTURBED AREA. SUITABLE TOPSOIL SHALL BE IMPORTED TO SITE IF INADEQUATE QUANTITIES OF SUITABLE TOPSOIL EXIST ON SITE. ADEQUACY OF SOIL TO BE DETERMINED BY SITE GEOTECHNICAL ENGINEER IN CONJUNCTION WITH THE LANDSCAPE ARCHITECT. SOIL AMENDMENTS SHALL BE ADDED AS REQUIRED. ALL UNSUITABLE MATERIAL SHALL BE DISPOSED OF PROPERLY. SITE GEOTECHNICAL ENGINEER SHALL ALSO BE CONSULTED DURING WINTER GRADING OPERATIONS.

PROPOSED SINGLE FAMILY DWELLING

PROJECT ADDRESS: STENTON AVENUE, PLYMOUTH MEETING, PA 19462

MUNICIPALITY: WHITEMARSH TOWNSHIP COUNTY: MONTGOMERY COUNTY

PLAN SET: EARTH DISTURBANCE PERMIT PLAN SET

SHEET NAME: EROSION AND SEDIMENTATION CONTROL PLAN

OWNER / APPLICANT: STENTON AVENUE TRUST
 C/O FRED ZASPEL
 20 LIMEKILN PIKE
 GLENSIDE, PA 19038

DATE: SEPTEMBER 18, 2025
 SCALE: 2025-261-2051
 ONE CALL NUMBER: CCY
 DRAWN BY: 25-036
 PROJECT NUMBER:

PREPARED BY: YOHN ENGINEERING, LLC
 P.O. BOX 26094
 COLLEGEVILLE, PA 19426
 610-489-4580
 WWW.YOHNENGINEERING.COM

SEAL: REGISTERED PROFESSIONAL ENGINEER CHRISTOPHER C. YOHN PE073703

3 OF 4

2 01/19/26 STC
 1 10/30/25 STC
 REV DATE COMMENTS

SCALE: 1" = 20'

NOTES: ALL DOCUMENTS PREPARED OR FINISHED BY ENGINEER AND PROPERTY INTEREST INCLUDES THE COPYRIGHT AND THE RIGHT OF REPRODUCTION IN WHOLE OR IN PART. ANY REPRODUCTION OF THIS DOCUMENT WITHOUT THE WRITTEN PERMISSION OF THE ENGINEER OR ARCHITECT IS PROHIBITED. THE ENGINEER OR ARCHITECT SHALL BE RESPONSIBLE FOR THE ACCURACY OF ALL INFORMATION PROVIDED TO THE ENGINEER OR ARCHITECT. THE ENGINEER OR ARCHITECT SHALL NOT BE RESPONSIBLE FOR THE ACCURACY OF ANY INFORMATION PROVIDED TO THE ENGINEER OR ARCHITECT BY OTHERS. THE ENGINEER OR ARCHITECT SHALL NOT BE RESPONSIBLE FOR THE ACCURACY OF ANY INFORMATION PROVIDED TO THE ENGINEER OR ARCHITECT BY OTHERS.

STANDARD E&S PLAN NOTES:

- ALL EARTH DISTURBANCES, INCLUDING CLEARING AND GRUBBING AS WELL AS CUTS AND FILLS SHALL BE DONE IN ACCORDANCE WITH THE APPROVED E&S PLAN. A COPY OF THE APPROVED DRAWINGS (STAMPED, SIGNED AND DATED BY THE REVIEWING AGENCY) MUST BE AVAILABLE AT THE PROJECT SITE AT ALL TIMES. THE REVIEWING AGENCY SHALL BE NOTIFIED OF ANY CHANGES TO THE APPROVED PLAN PRIOR TO IMPLEMENTATION OF THOSE CHANGES. THE REVIEWING AGENCY MAY REQUIRE A WRITTEN SUBMITTAL OF THOSE CHANGES FOR REVIEW AND APPROVAL AT ITS DISCRETION.
- AT LEAST 3 DAYS PRIOR TO STARTING ANY EARTH DISTURBANCE ACTIVITIES, OR EXPANDING INTO AN AREA PREVIOUSLY UNMARKED, THE PENNSYLVANIA ONE CALL SYSTEM INC. SHALL BE NOTIFIED AT 1-800-242-1776 FOR THE LOCATION OF EXISTING UTILITIES.
- ALL EARTH DISTURBANCE ACTIVITIES SHALL PROCEED IN ACCORDANCE WITH THE SEQUENCE PROVIDED ON THE PLAN DRAWINGS. DEVIATION FROM THAT SEQUENCE MUST BE APPROVED IN WRITING FROM THE MUNICIPALITY PRIOR TO IMPLEMENTATION OF THE E&S PLAN.
- AREAS TO BE FILLED ARE TO BE CLEARED, GRUBBED, AND STRIPPED OF TOPSOIL TO REMOVE TREES, VEGETATION, ROOTS AND OTHER OBJECTIONABLE MATERIAL.
- CLEARING, GRUBBING, AND TOPSOIL STRIPPING SHALL BE LIMITED TO THOSE AREAS DESCRIBED IN EACH STAGE OF THE CONSTRUCTION SEQUENCE. CLEARING, GRUBBING AND TOPSOIL STRIPPING MAY NOT COMMENCE IN ANY STAGE OR PHASE OF THE PROJECT UNTIL THE E&S BMPs SPECIFIED BY THE BMP SEQUENCE FOR THAT STAGE OR PHASE HAVE BEEN INSTALLED AND ARE FUNCTIONING AS DESCRIBED IN THIS E&S PLAN.
- AT NO TIME SHALL CONSTRUCTION VEHICLES BE ALLOWED TO ENTER AREAS OUTSIDE THE LIMIT OF DISTURBANCE BOUNDARIES SHOWN ON THE PLAN MAPS. THESE AREAS MUST BE CLEARLY MARKED AND FENCED OFF BEFORE CLEARING AND GRUBBING OPERATIONS BEGIN.
- TOPSOIL REQUIRED FOR THE ESTABLISHMENT OF VEGETATION SHALL BE STOCKPILED AT THE LOCATION(S) SHOWN ON THE PLAN MAPS(S) IN THE AMOUNT NECESSARY TO COMPLETE THE FINISH GRADING OF ALL EXPOSED AREAS THAT ARE TO BE STABILIZED BY VEGETATION. EACH STOCKPILE SHALL BE PROTECTED IN THE MANNER SHOWN ON THE PLAN DRAWINGS. STOCKPILE HEIGHTS SHALL NOT EXCEED 15 FEET. STOCKPILE SLOPES SHALL BE 2:1V OR FLATTER.
- IMMEDIATELY UPON DISCOVERING UNFORESEEN CIRCUMSTANCES POSING THE POTENTIAL FOR ACCELERATED EROSION AND/OR SEDIMENT POLLUTION, THE OPERATOR SHALL IMPLEMENT APPROPRIATE BEST MANAGEMENT PRACTICES TO MINIMIZE THE POTENTIAL FOR EROSION AND SEDIMENT POLLUTION AND NOTIFY THE MUNICIPALITY.
- ALL BUILDING MATERIALS AND WASTES SHALL BE REMOVED FROM THE SITE AND RECYCLED OR DISPOSED OF IN ACCORDANCE WITH THE DEPARTMENT'S SOLID WASTE MANAGEMENT REGULATIONS AT 25 PA. CODE 2601.27 ET SEQ., 2711. NO BUILDING MATERIALS OR WASTES OR UNUSED BUILDING MATERIALS SHALL BE BURNED, BURIED, DUMPED, OR DISCHARGED AT THE SITE.
- ALL OFF-SITE WASTE AND BORROW AREAS MUST HAVE AN E&S PLAN APPROVED BY THE LOCAL CONSERVATION DISTRICT OR THE DEPARTMENT FULLY IMPLEMENTED PRIOR TO BE ACTIVATED.
- ALL GRADED AREAS SHALL BE PERMANENTLY STABILIZED IMMEDIATELY UPON REACHING FINISHED GRADE. CUT SLOPES IN COMPETENT BEDROCK AND ROCK FILLS NEED NOT BE VEGETATED. SEEDED AREAS WITHIN 50 FEET OF A SURFACE WATER, OR AS OTHERWISE SHOWN ON THE PLAN DRAWINGS, SHALL BE BLANKETED ACCORDING TO THE STANDARDS OF THIS PLAN.
- IMMEDIATELY AFTER EARTH DISTURBANCE ACTIVITIES CEASE IN ANY AREA OR SUBAREA OF THE PROJECT, THE OPERATOR SHALL STABILIZE ALL DISTURBED AREAS. DURING NON-GERMINATING MONTHS, MULCH OR PROTECTIVE BLANKETING SHALL BE APPLIED AS DESCRIBED IN THE PLAN. AREAS NOT AT FINISHED GRADE, WHICH WILL BE REACTIVATED WITHIN 1 YEAR, MAY BE STABILIZED IN ACCORDANCE WITH THE TEMPORARY STABILIZATION SPECIFICATIONS. THOSE AREAS WHICH WILL NOT BE REACTIVATED WITHIN 1 YEAR SHALL BE STABILIZED IN ACCORDANCE WITH THE PERMANENT STABILIZATION SPECIFICATIONS.
- PERMANENT STABILIZATION IS DEFINED AS A MINIMUM UNIFORM PERENNIAL 70% VEGETATIVE COVER OR OTHER PERMANENT NON-VEGETATIVE COVER WITH A DENSITY SUFFICIENT TO RESIST ACCELERATED EROSION, CUT AND FILL SLOPES SHALL BE CAPABLE OF RESISTING FAILURE DUE TO SLUMPING, SLIDING, OR OTHER MOVEMENTS.
- E&S BMPs SHALL REMAIN FUNCTIONAL AS SUCH UNTIL ALL AREAS TRIBUTARY TO THEM ARE PERMANENTLY STABILIZED OR UNTIL THEY ARE REPLACED BY ANOTHER BMP APPROVED BY THE MUNICIPALITY.
- UPON COMPLETION OF ALL EARTH DISTURBANCE ACTIVITIES AND PERMANENT STABILIZATION OF ALL DISTURBED AREAS, THE OWNER AND/OR OPERATOR SHALL CONTACT THE MUNICIPALITY FOR AN INSPECTION PRIOR TO REMOVAL/CONVERSION OF THE E&S BMPs.
- AFTER FINAL SITE STABILIZATION HAS BEEN ACHIEVED, TEMPORARY EROSION AND SEDIMENT BMPs MUST BE REMOVED OR CONVERTED TO PERMANENT POST CONSTRUCTION STORMWATER MANAGEMENT BMPs. AREAS DISTURBED DURING REMOVAL OR CONVERSION OF THE BMPs SHALL BE STABILIZED IMMEDIATELY. IN ORDER TO ENSURE RAPID REVEGETATION OF DISTURBED AREAS, SUCH REMOVAL/CONVERSIONS ARE TO BE DONE ONLY DURING THE GERMINATING SEASON.
- UPON COMPLETION OF ALL EARTH DISTURBANCE ACTIVITIES AND PERMANENT STABILIZATION OF ALL DISTURBED AREAS, THE OWNER AND/OR OPERATOR SHALL CONTACT THE MUNICIPALITY TO SCHEDULE A FINAL INSPECTION.
- FAILURE TO CORRECTLY INSTALL E&S BMPs, FAILURE TO PREVENT SEDIMENT-LADEN RUNOFF FROM LEAVING THE CONSTRUCTION SITE, OR FAILURE TO TAKE IMMEDIATE CORRECTIVE ACTION TO REMOVE FAILURE OF E&S BMPs MAY RESULT IN ADMINISTRATIVE, CIVIL, AND/OR CRIMINAL PENALTIES BEING INSTITUTED BY THE MUNICIPALITY AS DEFINED IN SECTION 602 OF THE PENNSYLVANIA CLEAN STREAMS LAW. THE CLEAN STREAMS LAW PROVIDES FOR UP TO \$10,000 PER DAY IN CIVIL PENALTIES, UP TO \$10,000 IN SUMMARY CRIMINAL PENALTIES, AND UP TO \$25,000 IN MISDEMEANOR CRIMINAL PENALTIES FOR EACH VIOLATION.
- CONCRETE WASH WATER SHALL BE HANDLED IN THE MANNER DESCRIBED ON THE PLAN DRAWINGS. IN NO CASE SHALL IT BE ALLOWED TO ENTER ANY SURFACE WATERS OR GROUNDWATER SYSTEMS.
- SEDIMENT BASINS AND/OR TRAPS SHALL BE KEPT FREE OF ALL CONSTRUCTION WASTE, WASH WATER, AND OTHER DEBRIS HAVING POTENTIAL TO CLOG THE BASIN/TRAP OUTLET STRUCTURES AND/OR POLLUTE THE SURFACE WATERS.
- SEDIMENT BASINS AND/OR TRAPS SHALL BE PROTECTED FROM UNAUTHORIZED ACTS BY THIRD PARTIES.
- ANY DAMAGE THAT OCCURS IN WHOLE OR IN PART AS A RESULT OF BASIN OR TRAP DISCHARGE SHALL BE IMMEDIATELY REPAIRED BY THE PERMITTEE IN A PERMANENT MANNER SATISFACTORY TO THE MUNICIPALITY, LOCAL CONSERVATION DISTRICT, AND THE OWNER OF THE DAMAGED PROPERTY.
- SOD OR EROSION CONTROL BLANKETING SHALL BE INSTALLED ON ALL SLOPES 4:1H:1V OR STEEPER, WITHIN 50 FEET OF A SURFACE WATER AND ON ALL OTHER DISTURBED AREAS SPECIFIED ON THE PLAN MAPS AND/OR DETAIL SHEETS.
- HAY OR STRAW MULCH MUST BE APPLIED AT 3.0 TONS PER ACRE.
- STRAW MULCH SHALL BE APPLIED IN LONG STRANDS, NOT CHOPPED OR FINELY BROKEN.
- GRADING AND EARTHMOVING OPERATIONS SHALL BE MINIMIZED DURING THE PERIOD FROM NOVEMBER 15 TO APRIL 1 WHEN RE-VEGETATION OF EXPOSED GROUND SURFACE IS DIFFICULT. MULCH, STRAW, STONE AND/OR SOD SHALL BE USED TO STABILIZE AREAS DENuded DURING THIS TIME PERIOD.
- THE RUNOFF CROSSING TO THE ADJACENT PROPERTIES DURING THE CONSTRUCTION PHASE OF THE PROJECT SHALL BE MANAGED SO THAT THE WATER QUALITY / QUANTITY IMPACT IS MINIMIZED TO THE ADJACENT PROPERTIES. ADDITIONAL DIVERSION BERMS, STONED CONSTRUCTION STAGING AREAS, AND INLETS/PIPING SHALL BE PROVIDED AS NECESSARY / DIRECTED IN ORDER TO ENSURE ACCEPTABLE CONDITIONS DURING THE CONSTRUCTION PHASE.
- ALL TOPSOIL SHALL REMAIN ONSITE UNLESS OTHERWISE DIRECTED BY THE OWNER.
- FILL MATERIAL AND TOPSOIL STOCKPILES AND ACCESS TO THEM SHALL NOT BE LOCATED WITHIN THE DRIPLINE OF EXISTING TREES.
- THE MAXIMUM TIME OF EXPOSURE FOR BARE SOIL AREAS SHALL BE TWENTY (20) DAYS BEFORE STABILIZATION MEASURES ARE IMPLEMENTED.

CLEAN FILL AND ENVIRONMENTAL DUE DILIGENCE NOTES:

- IF THE SITE WILL HAVE EXCESS FILL THAT WILL NEED TO BE EXPORTED TO AN OFF SITE LOCATION, THE RESPONSIBILITY OF CLEAN FILL DETERMINATION AND ENVIRONMENTAL DUE DILIGENCE RESTS ON THE APPLICANT. IF ALL CUT AND FILL MATERIALS WILL BE USED ON THE SITE, A CLEAN FILL DETERMINATION IS NOT REQUIRED BY THE OPERATOR UNLESS THERE IS A BELIEF THAT A SPILL OR RELEASE OF REGULATED SUBSTANCE OCCURRED ON SITE.
- APPLICANTS AND/OR OPERATORS MUST USE ENVIRONMENTAL DUE DILIGENCE TO ENSURE THAT THE FILL MATERIAL ASSOCIATED WITH THE PROJECT QUALIFIES AS CLEAN FILL. ALL FILL MATERIAL MUST BE USED IN ACCORDANCE WITH THE DEPARTMENT'S POLICY "MANAGEMENT OF FILL," DOCUMENT NUMBER 258-2182-773 A COPY OF THIS POLICY IS AVAILABLE ONLINE AS WWW.DEPWEB.STATE.PA.
- CLEAN FILL IS DEFINED AS: UNCONTAMINATED, NON-WATER SOLUBLE, NON-DECOMPOSABLE, INERT, SOLID MATERIAL. THE TERM INCLUDES SOIL, ROCK, STONE, DREDGED MATERIAL, USED ASPHALT, AND BRICK, BLOCK OR CONCRETE FROM CONSTRUCTION AND DEMOLITION ACTIVITIES THAT IS SEPARATE FROM OTHER WASTE AND IS RECOGNIZABLE AS SUCH. THE TERM DOES NOT INCLUDE MATERIALS PLACED IN OR ON THE WATERS OF THE COMMONWEALTH UNLESS OTHERWISE AUTHORIZED. (THE TERM "USED ASPHALT" DOES NOT INCLUDE MILLED ASPHALT OR ASPHALT THAT HAS BEEN PROCESSED FOR RE-USE).
- CLEAN FILL AFFECTED BY A SPILL OR RELEASE OF A REGULATED SUBSTANCE; FILL MATERIALS AFFECTED BY A SPILL OR RELEASE OF A REGULATED SUBSTANCE STILL QUALIFIES AS CLEAN FILL PROVIDED THE TESTING RESULTS THAT THE FILL MATERIAL CONTAINS CONCENTRATIONS OF REGULATED SUBSTANCES THAT ARE BELOW THE RESIDENTIAL LIMITS IN TABLES FP-1A AND FP-1B FOUND IN THE DEPARTMENT'S POLICY "MANAGEMENT OF FILL."
- ANY PERSON PLACING CLEAN FILL THAT HAS BEEN AFFECTED BY A SPILL OR RELEASE OF A REGULATED SUBSTANCE MUST USE FORM FP-001 TO CERTIFY THAT THE OPERATION OF THE FILL MATERIAL AND THE RESULTS OF THE ANALYTICAL TESTING TO QUALIFY THE MATERIAL AS CLEAN FILL. FORM FP-001 MUST BE RETAINED BY THE OWNER OF THE PROPERTY RECEIVING THE FILL. A COPY OF FORM FP-001 CAN BE FOUND AT THE END OF THIS PLAN.
- ENVIRONMENTAL DUE DILIGENCE: INVESTIGATIVE TECHNIQUES, INCLUDING, BUT NOT LIMITED TO, VISUAL PROPERTY INSPECTIONS, ELECTRONIC DATA BASE SEARCHES, REVIEW OF PROPERTY OWNERSHIP, REVIEW OF PROPERTY USE HISTORY, SANDBORN MAPS, ENVIRONMENTAL QUESTIONNAIRES, TRANSACTION SCREENS, ANALYTICAL TESTING, ENVIRONMENTAL ASSESSMENTS OR AUDITS. ANALYTICAL TESTING IS NOT A REQUIRED PART OF DUE DILIGENCE UNLESS VISUAL INSPECTION AND/OR REVIEW OF THE PAST LAND USE OF THE PROPERTY INDICATES THAT THE FILL MAY HAVE BEEN SUBJECTED TO A SPILL OR RELEASE OF REGULATED SUBSTANCE. IF THE FILL MAY HAVE BEEN AFFECTED BY A SPILL OR RELEASE OF A REGULATED SUBSTANCE, IT MUST BE TESTED TO DETERMINE IF IT QUALIFIES AS CLEAN FILL. TESTING SHOULD BE PERFORMED IN ACCORDANCE WITH APPENDIX A OF THE DEPARTMENT'S POLICY "MANAGEMENT OF FILL."
- FILL MATERIAL THAT DOES NOT QUALIFY AS CLEAN FILL IS REGULATED FILL. REGULATED FILL IS WASTE AND MUST BE MANAGED IN ACCORDANCE WITH THE DEPARTMENT'S MUNICIPAL OR RESIDUAL WASTE MANAGEMENT REGULATIONS BASED ON 25 PA. CODE CHAPTERS 287 RESIDUAL WASTE MANAGEMENT OR 271 MUNICIPAL WASTE MANAGEMENT. WHOEVER IS APPLICABLE.

TOPSOIL APPLICATION:

- GRADED AREAS SHOULD BE SCARIFIED OR OTHERWISE LOOSENED TO A DEPTH OF 2 TO 4 INCHES TO PERMIT BONDING OF THE TOPSOIL TO THE SURFACE AREAS AND TO PROVIDE A ROUGHENED SURFACE TO PREVENT TOPSOIL FROM SLIDING DOWN SLOPE.
- TOPSOIL SHOULD BE UNIFORMLY DISTRIBUTED ACROSS THE DISTURBED AREA TO A DEPTH OF 4 TO 8 INCHES MINIMUM - 2 INCHES ON FILL OUTSLOPES. SPREADING SHOULD BE DONE IN SUCH A MANNER THAT SOODING OR SEEDING CAN PROCEED WITH A MINIMUM OF ADDITIONAL PREPARATION OR TILLAGE. IRREGULARITIES IN THE SURFACE RESULTING FROM TOPSOIL PLACEMENT SHOULD BE CORRECTED IN ORDER TO PREVENT FORMATION OF DEPRESSIONS UNLESS SUCH DEPRESSIONS ARE PART OF THE FINISH PLAN.
- TOPSOIL SHOULD NOT BE PLACED WHILE THE TOPSOIL OR SUBSOIL IS IN A FROZEN OR MUDDY CONDITION, WHEN THE SUBSOIL IS EXCESSIVELY WET, OR IN A MANNER THAT MAY OTHERWISE BE DETRIMENTAL TO PROPER GRADING AND SEEDBED PREPARATION. COMPACTED SOILS SHOULD BE SCARIFIED 6 TO 12 INCHES ALONG CONTOUR WHEREVER POSSIBLE PRIOR TO SEEDING.

TURFGRASS ESTABLISHMENT:

- A SOIL TEST TO DETERMINE LIME AND FERTILIZER REQUIREMENTS. PROVIDES THE BEST GUIDE FOR PROPER TURFGRASS ESTABLISHMENT.
- ROUGH-GRADING
- TILL SOIL AND BRING AREA TO ROUGH-GRADE PRIOR TO LIMING OR FERTILIZATION.
- WHERE TOPSOIL IS TO BE REPLACED OR BROUGHT IN, FIRST RAKE OR GRAD THE AREA TO THE CONTOUR OF THE FINISHED GRADE TO FACILITATE UNIFORM DISTRIBUTION OF TOPSOIL.

LIMING

- WHERE A TEST HAS BEEN MADE, BROADCAST AND WORK INTO A 4 TO 6-INCH SOIL DEPTH TO MEET THE REQUIREMENT SHOWN BY THE TEST.
- WHERE LIME REQUIREMENT EXCEEDS 200 LBS. PER 1,000 SF, APPLY ONE HALF THE TOTAL REQUIREMENT, TILL, APPLY THE REMAINING ONE HALF, AND RETEST.

FERTILIZATION

- WHERE A TEST IS NOT AVAILABLE, BROADCAST AND WORK INTO A 4 TO 6-INCH SOIL DEPTH A MINIMUM OF 100 LBS. PER 1,000 SF.

BASIC FERTILIZATION

- WHERE A TEST HAS BEEN MADE, BROADCAST THE RECOMMENDED FERTILIZER AND WORK INTO THE SOIL TO A 4 TO 6-INCH DEPTH.
- WHERE A TEST HAS NOT BEEN MADE, BROADCAST AND WORK INTO THE SOIL TO A 4 TO 6-INCH DEPTH 25 TO 35 LBS. OF A 46-0-0 FERTILIZER OR EQUIVALENT PER 1,000 SF.

SOIL AMENDMENTS

- WHERE A TEST INDICATES THE SOIL HAS A LOW ORGANIC MATTER CONTENT, WORK THE RECOMMENDED ORGANIC MATTER INTO THE SOIL TO A 2 TO 4-INCH DEPTH BEFORE APPLYING THE STARTER FERTILIZER.
- REFUSE SEEDS, PEAT, MOSS PEAT, OR A COMBINATION OF THE TWO MATERIALS IS RECOMMENDED AS A SOURCE OF ORGANIC MATTER.

TILLAGE

- TILL SEEDBED TO A 4 TO 6-INCH DEPTH MAKING SURE THE LIMESTONE (OR OTHER MATERIAL IF REQUIRED) IS UNIFORMLY MIXED THROUGHOUT THE SOIL PROFILE. POCKETS OF LIMESTONE, AMENDMENTS OR FERTILIZER MUST BE AVOIDED.

FINISH-GRADING

- RAKE AREA TO FINISH-GRADE PRIOR TO SEEDING. LIGHT ROLLING WILL INDICATE ANY LOW SPOTS OR OTHER IRREGULARITIES OF THE AREA.

STARTER FERTILIZATION

- IMMEDIATELY FOLLOWING FINISH-GRADING, BROADCAST AND WORK INTO THE TOP INCH OF SOIL 40 LBS. OF A 10-5-5, 10-6-4 OR 25 LBS. OF A 16-8-8 FERTILIZER OR THE EQUIVALENT PER 1,000 SF. THE FERTILIZER MUST BE TURF GRADE, HAVING AN APPROXIMATE 2-1-1 RATIO AND CONTAINING 35 PERCENT OR MORE OF THE TOTAL NITROGEN AS WATER INSOLUBLE OR CONTROLLED RELEASE NITROGEN.

SEEDING

- LATE SUMMER TO EARLY FALL IS THE BEST TIME FOR SEEDING PERMANENT TURFGRASS.
- SOW RECOMMENDED SEED MIXTURE ADAPTED TO USE AND CLIMATIC CONDITIONS OF THE AREA.
- DIVIDE TOTAL SEED QUANTITY INTO TWO EQUAL LOTS, SOWING ONE LOT IN ONE DIRECTION AND THE SECOND LOT AT RIGHT ANGLES TO THE FIRST WITH A MECHANICAL SEEDER OR SPREADER.

COVER SEED

- RAKE LIGHTLY OR DRAG AREA TO COVER SEED NO DEEPER THAN 1/4 IN. SEED-SOIL CONTACT
- ROLL LIGHTLY TO FIRM SOIL AROUND SEED.

MULCHING

- MULCH SEEDED AREA WITH CLEAN STRAW OR MARSH HAY AT 3.0 TONS PER ACRE. LIGHT MULCHES (SOME SOIL SHOWING THROUGH MULCH) MAY BE LEFT ON THE AREA TO DECOMPOSE. HEAVY MULCHES (COMPLETE SOIL COVERAGE) SHOULD BE REMOVED FROM THE AREA WITHIN A FEW DAYS AFTER SEED GERMINATION.

PERMANENT SEED MIXTURES

| SPECIES | % OF MIXTURE | SEED RATE |
|---|------------------|-----------------|
| SUNNY AREAS AND WELL-DRAINED SOILS | | |
| KENTUCKY BLUEGRASS | 100% | 2-3 LB/1,000 SF |
| KENTUCKY BLUEGRASS PERENNIAL RYEGRASS | 80-90% 10-20% | 3-4 LB/1,000 SF |
| KENTUCKY BLUEGRASS FINE FESCUES | 40-60% 30-40% | 3-4 LB/1,000 SF |
| KENTUCKY BLUEGRASS PERENNIAL RYEGRASS | 10-20% | |
| PARTIALLY SHADED AREAS | | |
| TURF-TYPE TALL FESCUE | 100% | 6-8 LB/1,000 SF |
| TURF-TYPE PERENNIAL RYEGRASS | 100% | 4-5 LB/1,000 SF |
| HEAVY SHADE, WELL-DRAINED SOILS | | |
| FINE FESCUES | 40-50% | 4 LB/1,000 SF |
| KENTUCKY BLUEGRASS PERENNIAL RYEGRASS | 10-20% | |
| FINE FESCUES | 100% | 4-5 LB/1,000 SF |
| TURF-TYPE TALL FESCUE | 100% | 6-8 LB/1,000 SF |
| HEAVY SHADE, POORLY-DRAINED SOILS | | |
| FINE FESCUES | 100% | 4-5 LB/1,000 SF |
| ROUGH BLUEGRASS | 100% | 2-3 LB/1,000 SF |

TEMPORARY SEED MIXTURE

| SPECIES | % OF MIXTURE | SEED RATE |
|----------------------------|--------------|-----------------|
| ANNUAL OR ITALIAN RYEGRASS | 100% | 4-5 LB/1,000 SF |

SEED MIXTURE NOTES:

- SEEDING AND TURFGRASS INFORMATION TAKEN FROM THE PENN STATE COLLEGE OF AGRICULTURAL SCIENCES. FOR ADDITIONAL INFORMATION REFER TO HTTP://PLANTSOURCE/RESEARCH/CENTERS/TURF/
- THE PERCENTAGE OF WEED SEEDS SHOULD NOT EXCEED 1.0% BY WEIGHT IN THE CONTAINER. GOOD QUALITY GRASS SEED USUALLY CONTAINS NO MORE THAN 0.5% WEED SEEDS.
- SEEDS OR SEED MIXTURES CONTAINING TIMOTHY, MEADOW FESCUE, ORCHARDGRASS, TALL OATGRASS, ANNUAL RYEGRASS OR CLOVER ARE GENERALLY NOT SUGGESTED FOR TURFGRASS USE.
- ALL SEEDING RATES IN THIS PUBLICATION ARE IN POUNDS PER 1000 SQUARE FEET. IF CONVERTING TO AN ACRE BASIS, MULTIPLY BY 43.
- IT IS SUGGESTED THAT 3-5 VARIETIES OF KENTUCKY BLUEGRASS BE USED IN THE BLEND OR MIXTURE.
- WHEREVER SEED AND MULCH IS APPLIED BY HYDROSEEDING METHODS, THE SEED AND MULCH SHOULD BE APPLIED IN SEPARATE APPLICATIONS WITH THE SEED BEING APPLIED FIRST AND THE MULCH SPRAYED ON TOP OF THE SEED.
- IN CRITICAL AREAS (E.G. ADJACENT TO OR WITHIN 50 FEET OF STREAMS, PONDS, OR WETLANDS) A PROTECTIVE BLANKET SHOULD BE PROVIDED FOR ALL SEEDED AREAS.

STANDARD CONSTRUCTION DETAIL #4-7

STANDARD SILT FENCE (18" HIGH)

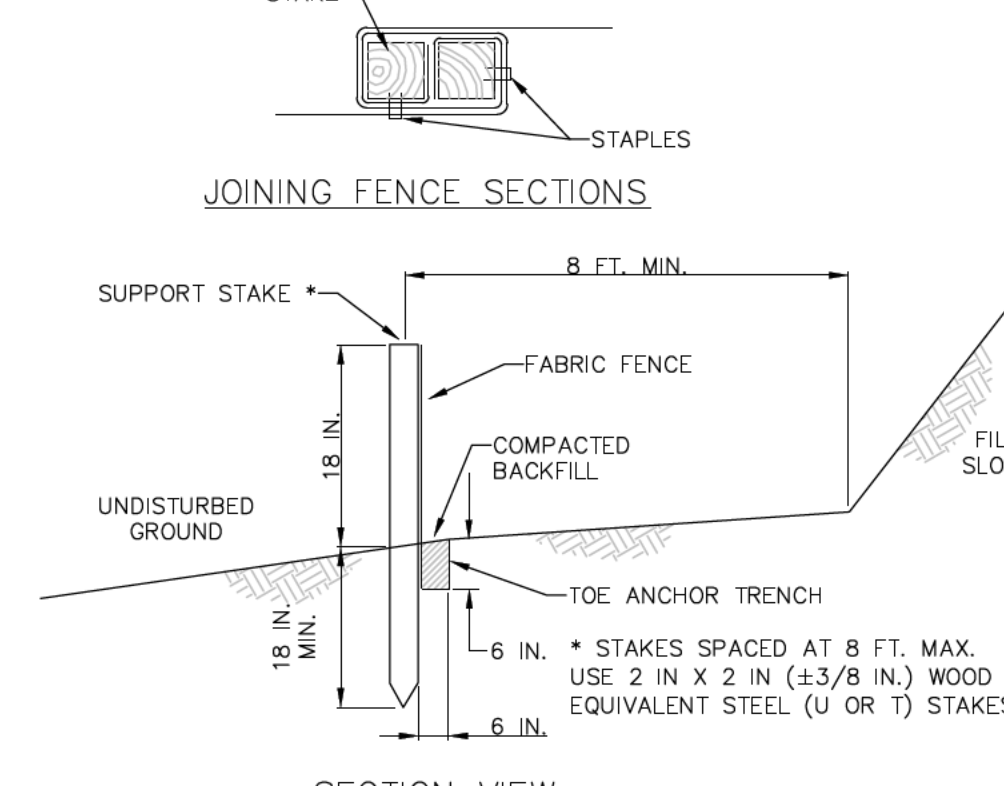

STANDARD CONSTRUCTION DETAIL #4-1

COMPOST FILTER SOCK



STANDARD CONSTRUCTION DETAIL #4-16

ROCK CONSTRUCTION ENTRANCE

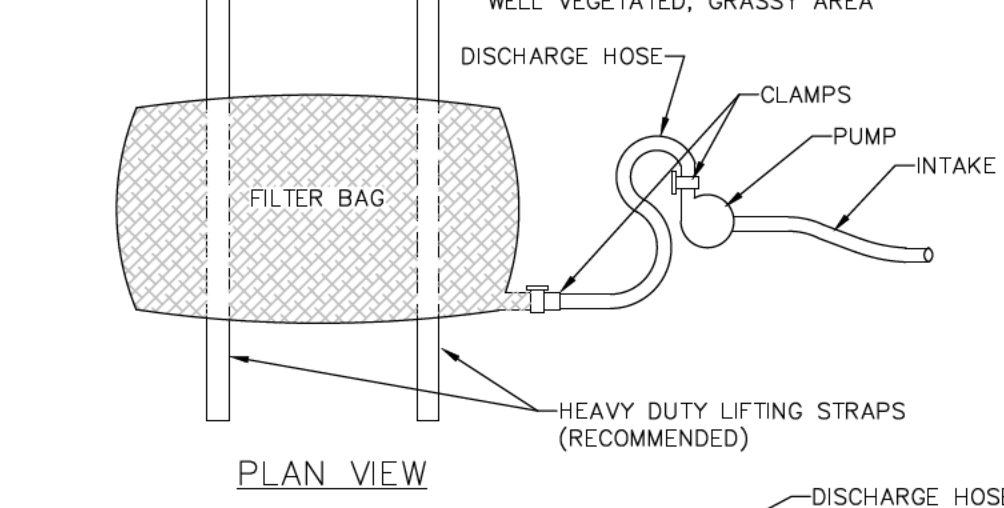

STANDARD CONSTRUCTION DETAIL #3-16

PUMPED WATER FILTER BAG

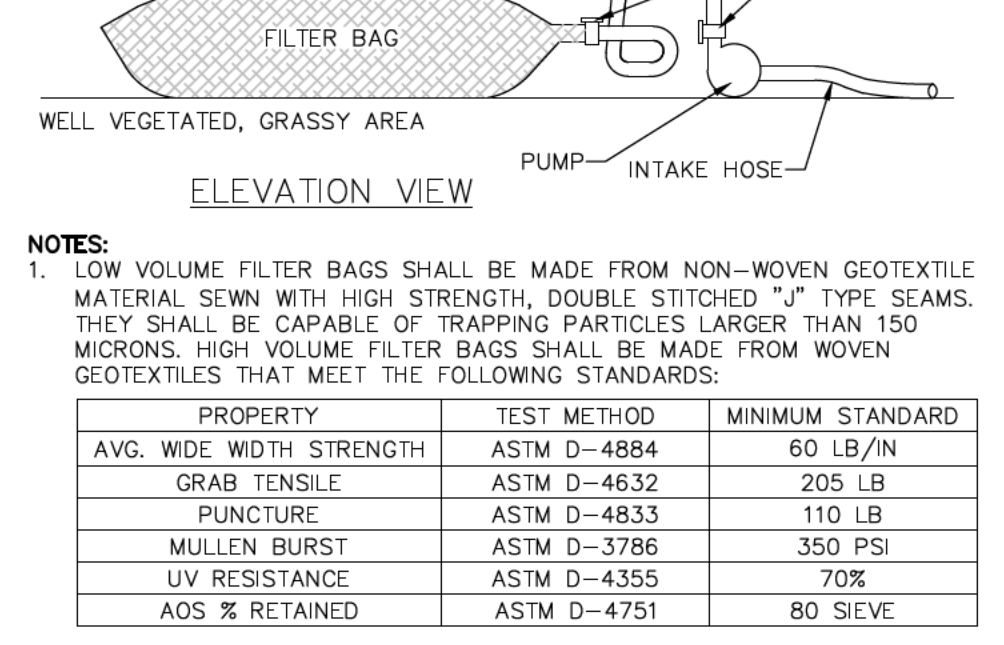

STANDARD CONSTRUCTION DETAIL #3-16

PUMPED WATER FILTER BAG

STANDARD CONSTRUCTION DETAIL #4-1

COMPOST FILTER SOCK

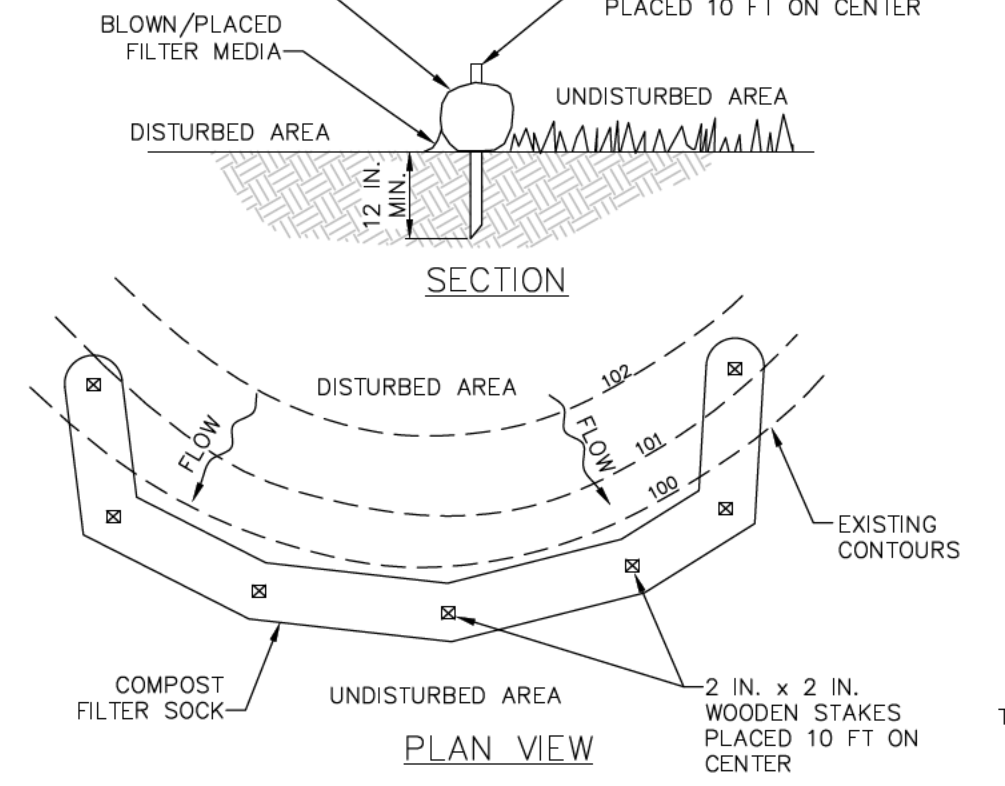

STANDARD CONSTRUCTION DETAIL #4-16

ROCK CONSTRUCTION ENTRANCE

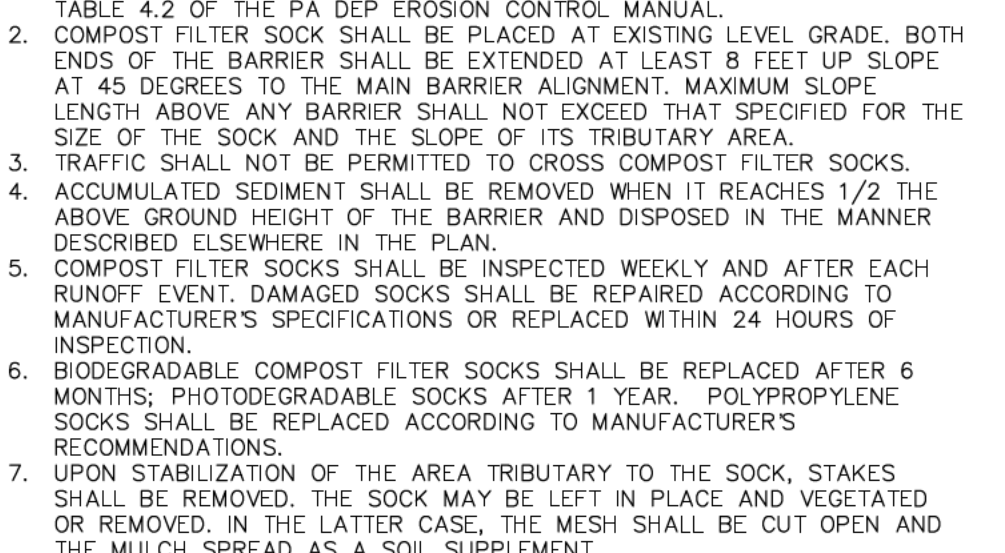

STANDARD CONSTRUCTION DETAIL #3-16

PUMPED WATER FILTER BAG

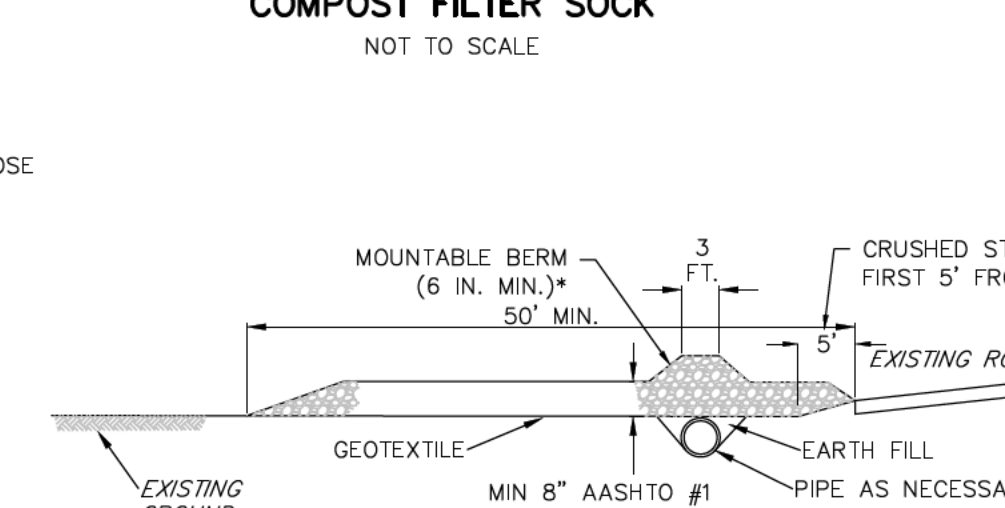

STANDARD CONSTRUCTION DETAIL #3-16

PUMPED WATER FILTER BAG

STANDARD CONSTRUCTION DETAIL #4-1

COMPOST FILTER SOCK

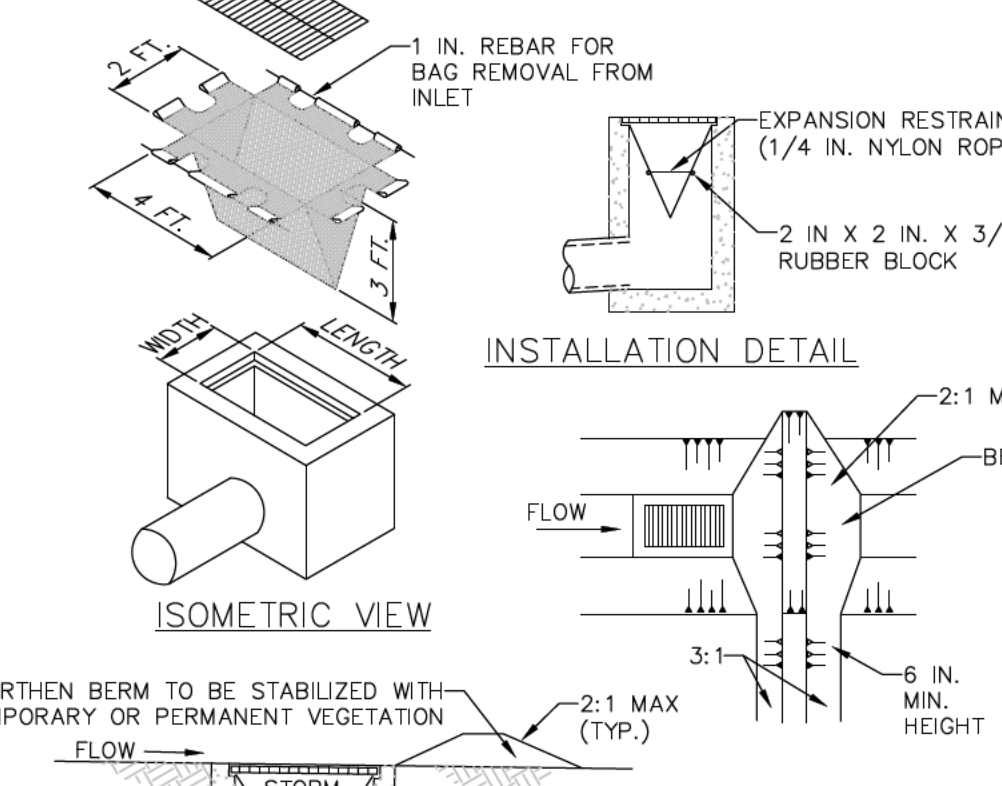

STANDARD CONSTRUCTION DETAIL #4-16

ROCK CONSTRUCTION ENTRANCE

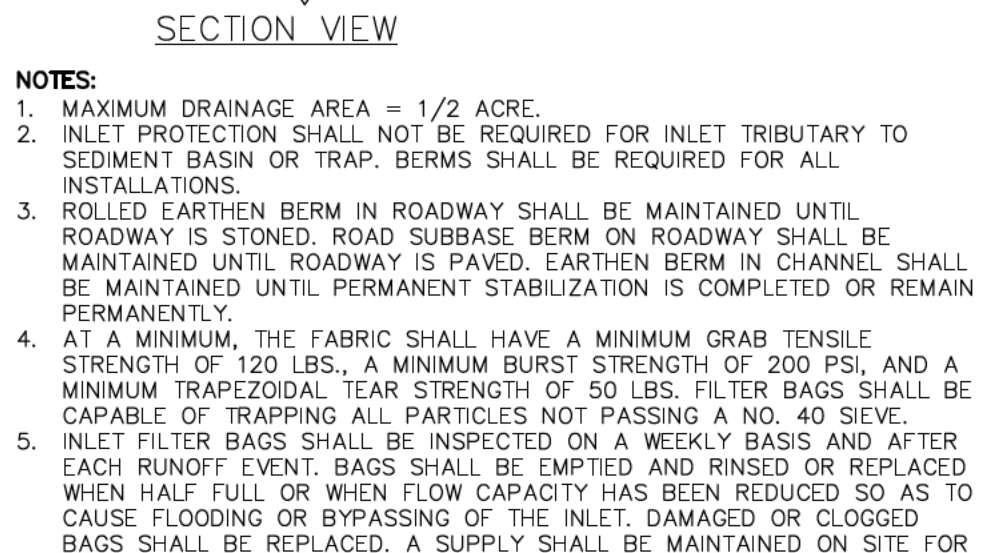

STANDARD CONSTRUCTION DETAIL #3-16

PUMPED WATER FILTER BAG

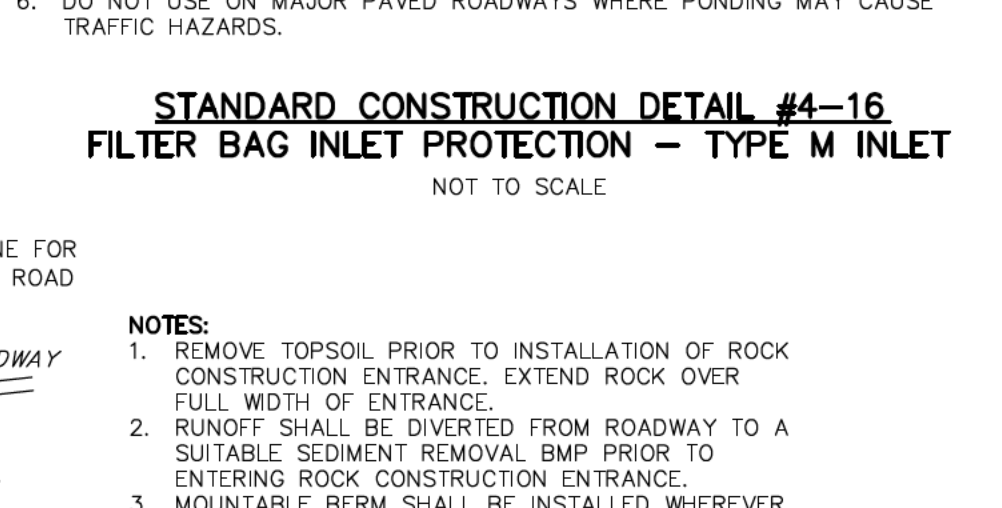

STANDARD CONSTRUCTION DETAIL #3-16

PUMPED WATER FILTER BAG

STANDARD CONSTRUCTION DETAIL #4-16

FILTER BAG INLET PROTECTION - TYPE M INLET

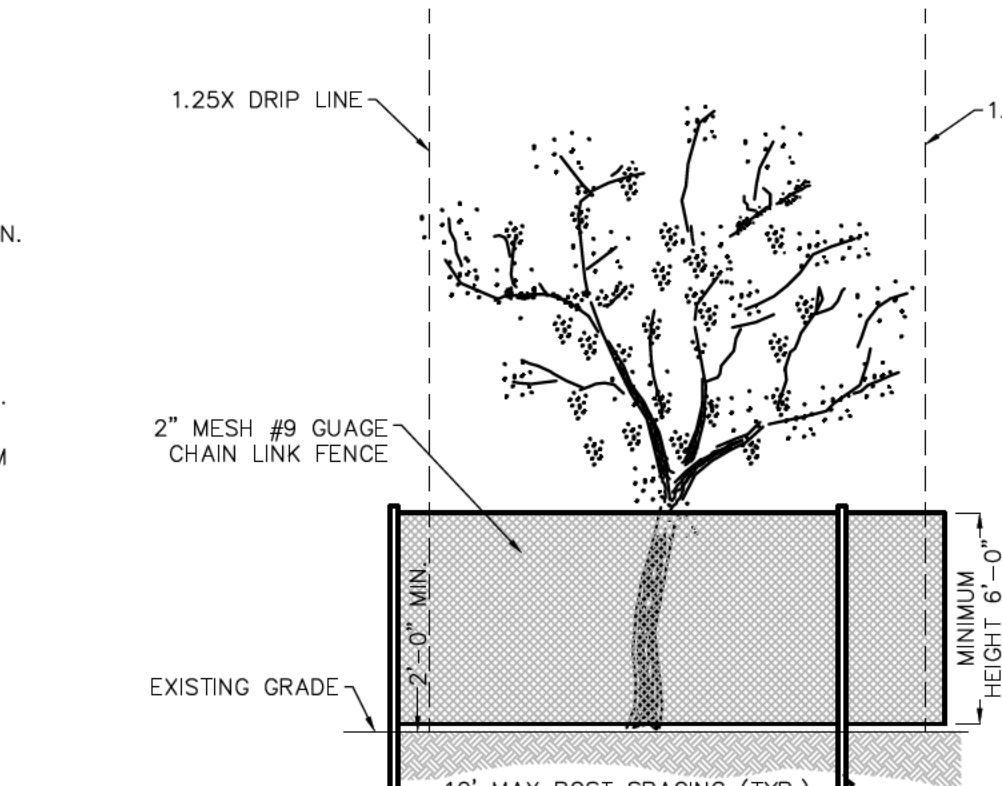

STANDARD CONSTRUCTION DETAIL #4-16

ROCK CONSTRUCTION ENTRANCE

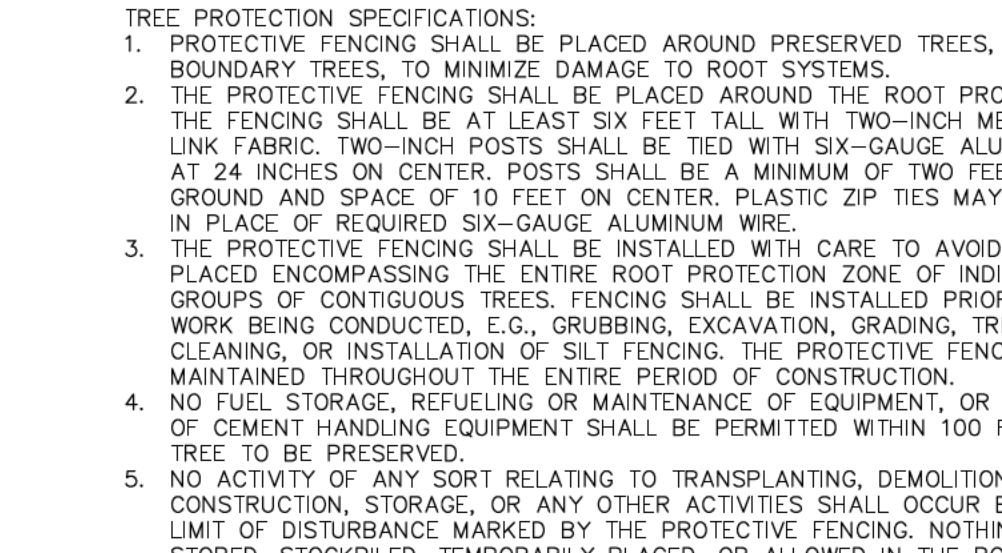

STANDARD CONSTRUCTION DETAIL #3-16

PUMPED WATER FILTER BAG

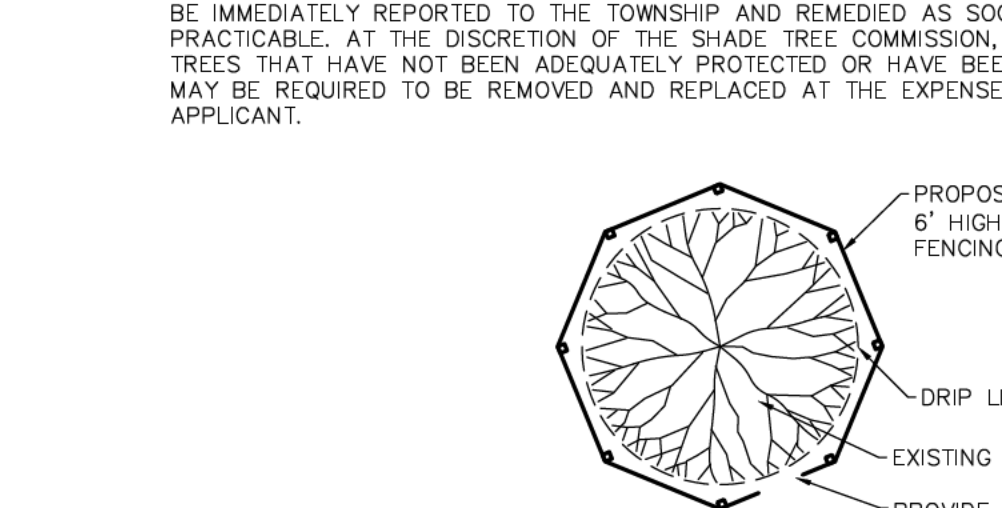

STANDARD CONSTRUCTION DETAIL #3-16

PUMPED WATER FILTER BAG

NOTES:

- SILT FENCE MUST COMPLETELY ENCRIRCLE STOCKPILES
- TOPSOIL SHALL NOT BE REMOVED FROM THE DEVELOPMENT SITE OR USED AS FILL
- TOPSOIL SHALL BE REMOVED FROM THE AREAS OF CONSTRUCTION AND STORED SEPARATELY
- CONSTRUCTION SHALL BE STABILIZED TO MINIMIZE EROSION DURING STORAGE
- UPON COMPLETION OF CONSTRUCTION, THE TOPSOIL SHALL BE UNIFORMLY REDISTRIBUTED ON THE SITE

NOTES:

- PROTECTIVE FENCING SHALL BE PLACED AROUND PRESERVED TREES, AND BOUNDARY TREES, TO MINIMIZE DAMAGE TO ROOT SYSTEMS
- THE PROTECTIVE FENCING SHALL BE PLACED AROUND THE ROOT PROTECTION ZONE. THE FENCING SHALL BE AT LEAST SIX FEET TALL WITH TWO-INCH MESH CHAIN LINK FENCING. TWO-INCH POSTS SHALL BE TIED WITH SIX-GAUGE ALUMINUM WIRES AT 24 INCHES ON CENTER. POSTS SHALL BE A MINIMUM OF TWO FEET IN THE GROUND AND SPACES OF 10 FEET ON CENTER. PLASTIC ZIP TIES MAY NOT BE USED IN PLACE OF REQUIRED SIX-GAUGE ALUMINUM WIRE
- THE PROTECTIVE FENCING SHALL BE INSTALLED WITH CARE TO AVOID ROOTS AND PLACED ENCOMPASSING THE ENTIRE ROOT PROTECTION ZONE OF INDIVIDUAL OR GROUPS OF CONTIGUOUS TREES. FENCING SHALL BE INSTALLED PRIOR TO ANY WORK BEING CONDUCTED, E.G., GRUBBING, EXCAVATION, GRADING, TRENCHING, CLEANING, OR INSTALLATION OF SILT FENCING. THE PROTECTIVE FENCING SHALL BE MAINTAINED THROUGHOUT THE ENTIRE PERIOD OF CONSTRUCTION
- NO FUEL STORAGE, REFUELING OR MAINTENANCE OF EQUIPMENT, OR WASH DOWN OF CEMENT HANDLING EQUIPMENT SHALL BE PERMITTED WITHIN 100 FEET OF ANY TREE TO BE PRESERVED
- NO ACTIVITY OF ANY SORT RELATING TO TRANSPORTING, DEMOLITION, GRADING, CONSTRUCTION, STORAGE, OR ANY OTHER ACTIVITIES SHALL OCCUR BEYOND THE LIMIT OF DISTURBANCE MARKED BY THE PROTECTIVE FENCING. NOTHING SHALL BE STORED, STOKED, TEMPORARILY PLACED, OR ALLOWED IN THE ROOT PROTECTION ZONE
- ANY DAMAGE TO THE FENCING OR ENCROACHMENT ON THE PROTECTED AREAS SHALL BE IMMEDIATELY REPORTED TO THE TOWNSHIP AND REMEDIATED AS SOON AS IS PRACTICABLE. AT THE DISCRETION OF THE SHADE TREE COMMISSION, PRESERVED TREES THAT HAVE NOT BEEN ADEQUATELY PROTECTED OR HAVE BEEN DAMAGED MAY BE REQUIRED TO BE REMOVED AND REPLACED AT THE EXPENSE OF THE APPLICANT.

NOTES:

- REMOVE TOPSOIL PRIOR TO INSTALLATION OF ROCK CONSTRUCTION ENTRANCE. EXTEND ROCK OVER FULL WIDTH OF ENTRANCE
- RUNOFF SHALL BE DIVERTED FROM ROADWAY TO A SUITABLE SEDIMENT REMOVAL BMP PRIOR TO ENTERING ROCK CONSTRUCTION ENTRANCE
- MOUNTABLE BERM SHALL BE INSTALLED WHEREVER OPTIONAL CULVERT PIPE IS USED AND PROPER PIPE COVER AS SPECIFIED BY MANUFACTURER IS NOT OTHERWISE PROVIDED. PIPE SHALL BE SIZED APPROPRIATELY FOR SIZE OF DITCH BEING CROSSED
- MAINTENANCE: ROCK CONSTRUCTION ENTRANCE THICKNESS SHALL BE CONSTANTLY MAINTAINED TO THE SPECIFIED DIMENSIONS BY ADDING ROCK. A STOCKPILE SHALL BE MAINTAINED ON SITE FOR THIS PURPOSE. ALL SEDIMENT DEPOSITED ON PAVED ROADWAYS SHALL BE REMOVED AND RETURNED TO THE CONSTRUCTION SITE IMMEDIATELY IF EXCESSIVE AMOUNTS OF SEDIMENT ARE BEING DEPOSITED ON ROADWAY. EXTEND LENGTH OF ROCK CONSTRUCTION ENTRANCE BY 50 FOOT MINIMUM TO PREVENT CONDITION IS ALLEVATED OR INSTALL WASH RACK. WASHING THE ROADWAY OR SWEEPING THE DEPOSITS INTO ROADWAY DITCHES, SEWERS, CULVERTS, OR OTHER DRAINAGE COURSES IS NOT ACCEPTABLE.

NOTES:

- LOW VOLUME FILTER BAGS SHALL BE MADE FROM NON-WOVEN GEOTEXTILE MATERIAL SEWN WITH HIGH STRENGTH, DOUBLE STITCHED "J" TYPE SEAMS. THEY SHALL BE CAPABLE OF TRAPPING PARTICLES LARGER THAN 150 MICRONS. HIGH VOLUME FILTER BAGS SHALL BE MADE FROM WOVEN GEOTEXTILES THAT MEET THE FOLLOWING STANDARDS:

| PROPERTY | TEST METHOD | MINIMUM STANDARD |
|-----------------|-------------|------------------|
| AVG. WIDE WIDTH | ASTM D-4884 | 60 LB/IN |
| GRAB TENSILE | ASTM D-4632 | 205 LB |
| PUNCTURE | ASTM D-4833 | 110 LB |
| MULLEN BURST | ASTM D-3786 | 350 PSI |
| UV RESISTANCE | ASTM D-4355 | 70% |
| AOS % RETAINED | ASTM D-4751 | 80 SIEVE |

NOTES:

- A SUITABLE MEANS OF ACCESSING THE BAG WITH MACHINERY REQUIRED FOR DISPOSAL PURPOSES SHALL BE PROVIDED. FILTER BAGS SHALL BE REPLACED WHEN THEY BECOME 1/2 FULL OF SEDIMENT. SPARE BAGS SHALL BE KEPT AVAILABLE FOR REPLACEMENT OF THOSE THAT HAVE FAILED OR ARE FILLED. BAGS SHALL BE PLACED ON STRAPS TO FACILITATE REMOVAL UNLESS BAGS COME WITH



January 27, 2026

Christopher C. Yohn, PE
Yohn Engineering, LLC
P.O. Box 26094
Collegeville, PA 19426

**RE: Earth Disturbance Permit Review
Stenton Avenue Trust
Whitemarsh Township, Montgomery County, Pennsylvania
Permit #2025-22
Our Project Number 2025-01098**

Dear Mr. Yohn:

In reference to the above-mentioned property, we have reviewed plans prepared by Yohn Engineering, LLC, dated September 18, 2025, and last revised January 19, 2026. The following comments must be resolved before an earth disturbance permit can be issued for this project.

CHAPTER 58 - GRADING, EROSION CONTROL, STORMWATER MANAGEMENT AND BEST MANAGEMENT PRACTICES

| <u>Section</u> | <u>Description</u> |
|-----------------|---|
| 1. 58-17 | There is an errant dimension label over the Post Construction Stormwater Management Installation Note on Sheet 2, which must be removed. The Construction Notes on Sheet 2 must be revised as follows: <ul style="list-style-type: none">Note 3 must be revised to state that the permit is required from PennDOT.Note 4 must be revised to state that the permit is required from the Whitemarsh Authority. |
| 2. 58-28(D)(11) | The plans must be revised so that the proposed contour line representing an elevation of 241, near the stormwater BMP, does not extend off of the subject property. |

CHAPTER 55 - TREE PROTECTION STANDARDS

| <u>Section</u> | <u>Description</u> |
|------------------|--|
| 3. 55-4(C) | This section of the ordinance requires that the tree survey plan shall be reviewed by the Shade Tree Commission in a public meeting. |
| 4. 55-4(C)(4)(b) | The plans show tree protection fencing within the root protection zone, as established by one of the following two means, whichever is greater: [1] Calculated at 1.25 feet (radius) per one inch of (DBH) diameter breast height. [2] A circle with a radius extending from a tree's trunk to a point no less than the furthest crown dripline. |

401 Plymouth Road | Suite 150 | Plymouth, PA 19462 | Phone: 610-489-4949 | Fax: 610-489-8447

| <u>Section</u> | <u>Description</u> |
|----------------|--|
| 5. 55-4(D)(6) | We defer to the Shade Tree Commission with regard to compliance with the requirements of this section of the ordinance, which requires that every tree determined to be living and healthy, with a DBH of 6 inches or greater and which is designated to be removed or which is destroyed, shall be replaced with one or more new Canopy trees of a type and species approved by the Township with a trunk diameter of not less than 3 inches in caliper. The total caliper of replacement trees, measured at 6 inches above the ground line, shall equal or exceed the DBH of the tree removed. |

ADDITIONAL COMMENTS

6. The applicant must obtain a Highway Occupancy Permit the Pennsylvania Department of Transportation for the proposed work within the right of way of Stenton Avenue (SR 3003).
7. The Lot labels should be reviewed for correctness and revised as necessary.

Any future submission of the design plans for this project must be accompanied by a letter, prepared by the applicant's engineer, which addresses each of the comments contained in this report. Should you have any questions regarding this matter, please do not hesitate to contact me at this office.

Sincerely,



Krista Heinrich, P.E.
Township Engineer
Gilmore & Associates, Inc.

cc: Charles L. Guttenplan, AICP – Director of Planning and Zoning
Samantha Zrillo –Township Planner
Sean Kilkenny, Esq.; The Law Offices of Sean Kilkenny, LLC – Township Solicitor (*via email*)
Mr. Robert A. Sztubinski, B.C.O. – Director of Building & Codes (*via email*)
Stenton Avenue Trust c/o Fred Zaspel – Owners/Applicants
Rockwell Custom – Owner's Contractor (*via email: connor@rockwellcustom.com*)

An American sycamore (yellow star) that we planted in 2021 has almost quadrupled in diameter and tripled in height since planting. We see this as a great opportunity to plant some more water-loving native trees to soak up and slow rainwater before it runs off into the downstream neighborhood.

